

HEDON

Rimadesio

WITH HEDON, THE WALK-IN CLOSET BECOMES A REAL ROOM: CHARACTERISED BY THE UTMOST GEOMETRIC RIGOUR AND HORIZONTAL ELEMENTS OF MINIMAL THICKNESS. DESIGNED BY GIUSEPPE BAVUSO, IT STANDS OUT FOR ITS MINIMALIST STYLE AND REFINED ATTENTION TO EVERY DETAIL, FROM THE ACCESSORIES TO THE CABINETS FOR ORGANISING WARDROBE SPACE.

IT Con Hedon la cabina armadio diventa una vera e propria stanza: un sistema modulare dal massimo rigore geometrico, caratterizzato da elementi orizzontali di minimo spessore. Progettata da Giuseppe Bavuso, si distingue per uno stile minimale e ricercato in ogni dettaglio, dagli accessori ai contenitori per l'organizzazione dello spazio armadio.

DE Mit Hedon wird der begehbare Kleiderschrank zu einem eigenständigen Raum: zu einem modularen System von höchster geometrischer Strenge, geprägt von horizontalen Elementen mit minimaler Materialstärke. Entworfen von Giuseppe Bavuso, zeichnet sich Hedon durch einen minimalistischen, bis ins Detail durchdachten Stil aus – von den Accessoires bis zu den Elementen zur Organisation des Stauraums.

FR Avec Hedon, le dressing devient une pièce à part entière: un système modulaire d'une rigueur géométrique maximale, caractérisé par des éléments horizontaux d'épaisseur minimale. Conçu par Giuseppe Bavuso, il se distingue par son style minimaliste et le soin apporté à chaque détail, des accessoires aux rangements pour organiser l'espace de la garde-robe.

ES Con Hedon el vestidor se convierte en una auténtica habitación: un sistema modular de máximo rigor geométrico, caracterizado por sus elementos horizontales de espesor mínimo. Diseñado por Giuseppe Bavuso, destaca por su estilo minimalista y una refinada atención a cada detalle, desde los accesorios hasta los contenedores para organizar el espacio del armario.

RU Благодаря Hedon гардеробный шкаф превращается в полноценную комнату. Это модульная система строгой геометрической формы с характерными ультратонкими горизонтальными элементами. Джузеппе Бавусо выполнил ее в минималистичном стиле с вниманием к каждой детали – от фурнитуры до тумб, служащих для организации пространства шкафа.

汉语 Hedon 步入式衣帽间精彩演绎房间的真实面貌: Hedon 为几何结构极其严谨的模块化系统, 厚度极薄的水平元素为设计亮点。由 Giuseppe Bavuso 研发, 简约风格为其独特出众的印记, 从各式配件到衣柜空间的收纳陈列柜, 每处细节尽显考究精神。



Structure: 304 platino
Groove fabric panels: T213 jasmine
Wooden shelves: 711 rovere
Glass shelves: 63 grigio trasparente
Suspended units fronts:
67 riflettente chiaro, 701 rovere taiga
Floor base in synthetic leather: 160 miele
Drawer floor unit: 137 platino opaco

In this photo
Armchairs: Nest
Sliding panels: Velaria
Carpet: Miglio
Coffee table: Tray
Pouf: Tray

EN Hedon is always custom made in height and width and allows you to create spaces designed for personal organisation, combining visual elegance and total design freedom. The panel's aluminium structure features a retractable electrified rack, into which all the system's exclusive accessories can be inserted, allowing them to be freely repositioned over time, easily adapting to new functional needs.

IT Hedon è sempre realizzata su misura in altezza e larghezza e consente di creare spazi dedicati all'ordine personale, unendo eleganza visiva e totale libertà progettuale. La struttura in alluminio del pannello è dotata di una cremagliera elettrificata a scomparsa, nella quale possono essere inseriti tutti gli accessori esclusivi del sistema, consentendo il loro libero riposizionamento nel tempo, adattandosi facilmente a nuove esigenze funzionali.

DE Hedon wird in Höhe und Breite stets nach Maß gefertigt und ermöglicht die Gestaltung von Räumen für Ihre individuelle Organisation, in denen visuelle Eleganz mit vollständiger gestalterischer Freiheit verbunden ist. Die Aluminiumstruktur des Paneels ist mit einer verdeckt integrierten, elektrifizierten Schiene ausgestattet, in die alle exklusiven Systemelemente eingesetzt werden können. Dadurch lassen sich die Komponenten jederzeit frei neu positionieren und flexibel an veränderte funktionale Anforderungen anpassen.

FR Hedon est toujours réalisé sur mesure en hauteur et en largeur, et vous permet de créer des espaces dédiés à votre aménagement personnel, en alliant élégance visuelle et liberté de conception totale. La structure en aluminium du panneau comprend un rack électrifié rétractable, dans lequel tous les accessoires exclusifs du système peuvent être insérés, en permettant ainsi de les repositionner librement au fil du temps et de s'adapter facilement aux nouveaux besoins fonctionnels.

ES Hedon se realiza siempre a medida en altura y anchura y permite crear espacios dedicados al orden personal, que combinan elegancia visual y total libertad proyectual. La estructura de aluminio del panel cuenta con un rack electrificado retráctil, en el que se pueden insertar todos los accesorios exclusivos del sistema, permitiendo reposicionarlos libremente a lo largo del tiempo para adaptarse fácilmente a nuevas necesidades funcionales.

RU Hedon — это всегда индивидуальное решение: система изготавливается точно по размерам высоты и ширины. Она позволяет создавать пространства для упорядоченного размещения личных вещей, сочетая внешнюю элегантность с абсолютной гибкостью планировочных решений. В алюминиевый каркас панелей встроена скрытая электрифицированная направляющая электроприводом, на которую могут устанавливаться все эксклюзивные элементы системы. С ее помощью их можно переставить в любое время, чтобы адаптировать гардеробную под меняющиеся потребности.

汉语 Hedon 的高度和宽度皆能够按尺寸定制，您可根据自己的喜好打造专属空间，将雅致的视觉效果与自由的灵活设计相互融蕴。铝制结构面板配备隐藏式电力层板轨道装置，可将系统的所有专用配件收入其中，随时间推移，可将配件再次自由定位，轻松更新功能性需求。



Structure: 304 platino
Glass drawer front and top: 67 riflettente chiaro
Wooden drawer front: 701 rovere taiga
Drawers groove fabric internal cladding: T213 jasmine



Structure: 304 platino
Groove fabric panels: T213 jasmine
Ceiling clothes-hanger bar in satin stainless steel
covered with synthetic leather: 160 miele
Floor unit with drawer: 137 platino opaco

In this photo
Armchair: Nest
Carpet: Miglio
Coffee table: Tray



Structure: 304 platino
Groove fabric panels: T213 jasmine
Wooden shelves: 711 rovere
Glass shelves: 63 grigio trasparente
Suspended units fronts: 67 riflettente chiaro, 711 rovere
Accessories and floor base in synthetic leather: 160 miele

In this photo
Carpet: Miglio
Pouf: Tray



Structure: 304 platino
Groove fabric panels: T213 jasmine
Wooden shelves with led-spotlight: 711 rovere
Clothes-hanger bar for shelf covered
with synthetic leather: 160 miele



Structure: 304 platino
 Groove fabric panels: T213 jasmine
 Wooden shelves and pullover-holder: 711 rovere
 Glass shelves: 63 grigio trasparente
 Suspended units top in synthetic leather: 160 miele
 Suspended unit drawer fronts: 701 rovere taiga
 Shoe shelves and floor base in synthetic leather: 160 miele

In this photo
 Armchair: Nest
 Carpet: Miglio
 Coffee table: Tray
 Pouf: Tray



Structure: 304 platino
Wooden shelves and pullover-holder: 711 rovere
Glass shelves: 63 grigio trasparente
Suspended units top in synthetic leather: 160 miele
Suspended unit drawer fronts: 701 rovere taiga
Shoe shelves and floor base in synthetic leather: 160 miele

EN Hedon offers a unique level of customisation in the world of walk-in closets, with over 300 finishes available, to ensure maximum freedom of expression. Fabrics, synthetic leather, raffia, litech, glossy or matt lacquered glass, different wood veneers and special materials expand the compositional and aesthetic possibilities. Completely customisable and suited to any architectural style, it allows you to freely position shelves and cabinets, creating neat or more articulated geometries.

IT Hedon offre un livello di personalizzazione unico nel mondo delle cabine armadio, con oltre 300 finiture disponibili, per garantire la massima libertà espressiva. Tessuti, similpelle, rafia, litech, vetro laccato lucido o opaco, essenze e materiali speciali ampliano le possibilità compositive ed estetiche. Completamente su misura e adattabile a ogni contesto architettonico, consente di posizionare liberamente ripiani e contenitori, creando geometrie ordinate o articolate.

DE Hedon bietet ein im Bereich der begehbaren Kleiderschränke einzigartiges Maß an Individualisierung, mit über 300 verfügbaren Ausführungen für maximale gestalterische Freiheit. Stoffe, Kunstleder, Raffia, Litech, glänzend oder matt lackiertes Glas, Holz und spezielle Materialien erweitern die kompositorischen und ästhetischen Möglichkeiten. Vollständig maßgefertigt und an jeden architektonischen Kontext anpassbar, erlaubt Hedon die freie Positionierung von Böden und Behältern und die Ausbildung einfacher oder stärker differenzierter Geometrien.

FR Hedon offre un niveau de personnalisation unique dans le monde des dressings, avec plus de 300 finitions disponibles, pour une liberté d'expression maximale. Tissus, simili cuir, raphia, litech, verre laqué brillant ou mat, bois et matériaux spéciaux élargissent les possibilités en termes de composition et d'esthétique. Entièrement réalisé sur mesure et adaptable à tout contexte architectural, il permet de positionner librement étagères et rangements, pour créer des géométries épurées ou articulées.

ES Hedon ofrece un nivel de personalización único en el mundo de los vestidores, con más de 300 acabados disponibles, para garantizar la máxima libertad de expresión. Tejidos, simil cuero, rafia, Litech, vidrio lacado translúcido u opaco, maderas y materiales especiales amplían las posibilidades compositivas y estéticas. Totalmente personalizable y adaptable a cualquier contexto arquitectónico, permite posicionar libremente estantes y contenedores, creando geometrías ordenadas o articuladas.

RU Система Hedon отличается уникальным для гардеробных шкафов уровнем индивидуализации: более 300 видов отделки обеспечивают максимальную свободу самовыражения. Текстиль и экокожа, рафия и инновационный Litech, глянцевое и матовое лакированное стекло, натуральное дерево и специальные материалы расширяют композиционные и эстетические возможности. Система полностью изготавливается под размер и адаптируется к любой архитектурной среде, полки и тумбы можно легко разместить различным образом, создавая безупречно упорядоченные или сложносоставные композиции.

汉语 在步入式衣帽间领域中，Hedon 提供无可比拟的定制体验，多达 300 种以上的饰面选择，为个性化表达赋予极大自由度。织物面料、仿真皮革、酒椰草材质、Litech、亮面或哑光效果的漆面玻璃、木材与特殊材质为组合与美学开创多样可能性。全按尺寸定制，可适应各式建筑环境，自由定位层板和收纳陈列柜，打造出井然有序、富有层次的几何外观。





Structure: 304 platino
 Groove fabric panels: T213 jasmine
 Glass shelves: 63 grigio trasparente
 Suspended units top and drawer front: 67 riflettente chiaro
 Pull-out accessories fronts: 711 rovere
 Floor base in synthetic leather: 160 miele



Structure: 304 platino
Nomad fabric panels: T201 gobi
Wooden shelves and pullover holder: 711 rovere
Glass shelves: 63 grigio trasparente
Suspended units top and drawer front: 67 riflettente chiaro
Drawer units fronts and drawer floor unit: 137 platino opaco
Suspended unit top and floor base, ceiling
clothes-hanger bar in synthetic leather: 160 miele









Structure and lacquered shelves: 303 bronzo
Nomad fabric panels: T201 gobi
Floor base, trousers rack and suspended units top
in synthetic leather: 154 argilla
Glass fronts: 136 bronzo opaco

EN Hedon can be 100% fully integrated with the Modulor boiserie, serving as a natural extension for the creation of walk-in closets in perfect continuity with the boiserie, even in corner layouts. The vertical rack conceals an exclusive and innovative power supply system for the LED lights, present on all accessories and panels, thereby avoiding complex electrical wiring and allowing the position of each individual accessory to be modified over time.

IT Hedon è un prodotto completamente integrabile con la boiserie Modulor, di cui è la naturale estensione per la realizzazione di cabine armadio in perfetta continuità e senza interruzioni con la boiserie, anche in composizioni ad angolo. Nella cremagliera verticale si nasconde un sistema esclusivo e innovativo di alimentazione per le luci led, presenti su tutti gli accessori e sui pannelli, che permette di evitare complessi cablaggi elettrici e di modificare nel tempo la posizione di ogni singolo accessorio.

DE Hedon lässt sich vollständig in das Wandverkleidungssystem Modulor integrieren und bildet dessen natürliche Erweiterung zur Realisierung von begehbaren Kleiderschränken in durchgehender räumlicher Kontinuität, auch in Eckkonfigurationen. In der vertikalen Schiene ist ein exklusives Stromversorgungssystem für die integrierten LED-Leuchten von Zubehör und Paneelen verborgen, das auf komplexe Verkabelungen verzichtet und eine flexible Neupositionierung der Elemente im Laufe der Zeit ermöglicht.

FR Hedon est un produit qui s'intègre parfaitement aux boiseries Modulor, dont il constitue le prolongement naturel pour créer des dressings dans une parfaite continuité et sans interruption avec lesdites boiseries, même dans des compositions d'angle. Le rack vertical abrite un système d'alimentation exclusif et innovant pour l'éclairage LED, présent sur tous les accessoires et panneaux, ce qui permet d'éviter les câblages électriques complexes, avec la possibilité de modifier la position de chaque accessoire au fil du temps.

ES Hedon es un producto totalmente integrable con el revestimiento Modulor, del que constituye la extensión natural para la creación de vestidores en perfecta continuidad y sin interrupciones con el revestimiento, incluso en composiciones esquineras. El rack vertical alberga un exclusivo e innovador sistema de alimentación para luces LED, presente en todos los accesorios y paneles, que permite evitar cableados eléctricos complejos y modificar la posición de cada accesorio a lo largo del tiempo.

RU Hedon безупречно интегрируется с буазери Modulor, становясь их естественным продолжением. Это позволяет создавать гардеробные шкафы, образующие с панелями абсолютно непрерывное визуальное пространство без стыков и переходов, в том числе в угловых секциях. В вертикальные направляющие встроена эксклюзивная инновационная система электропитания: светодиодная подсветка аксессуаров и панелей работает без сложного каблирования. Это позволяет в любой момент легко изменить положение любого элемента.

汉语 Hedon 是 Modulor 系统壁板的自然延伸，彼此能够相互集成、完美整合，打造出流畅、延续、完整的步入式衣帽间，转角处的组合也不例外。隐藏式直立层板轨道装置配备创新、独特的供电系统，用于为所有配件和面板的 LED 灯供电，从而免除 乱的电气布线，并可随心所欲更改每个附件的位置。



Structure and lacquered shelves: 303 bronzo
Nomad fabric panels: T201 gobi
Floor base, shelves, pull-out accessories,
suspended units top in synthetic leather: 154 argilla
Glass fronts: 136 bronzo opaco

In this photo
Wall partition system: Air system pure
Pouf: Tray

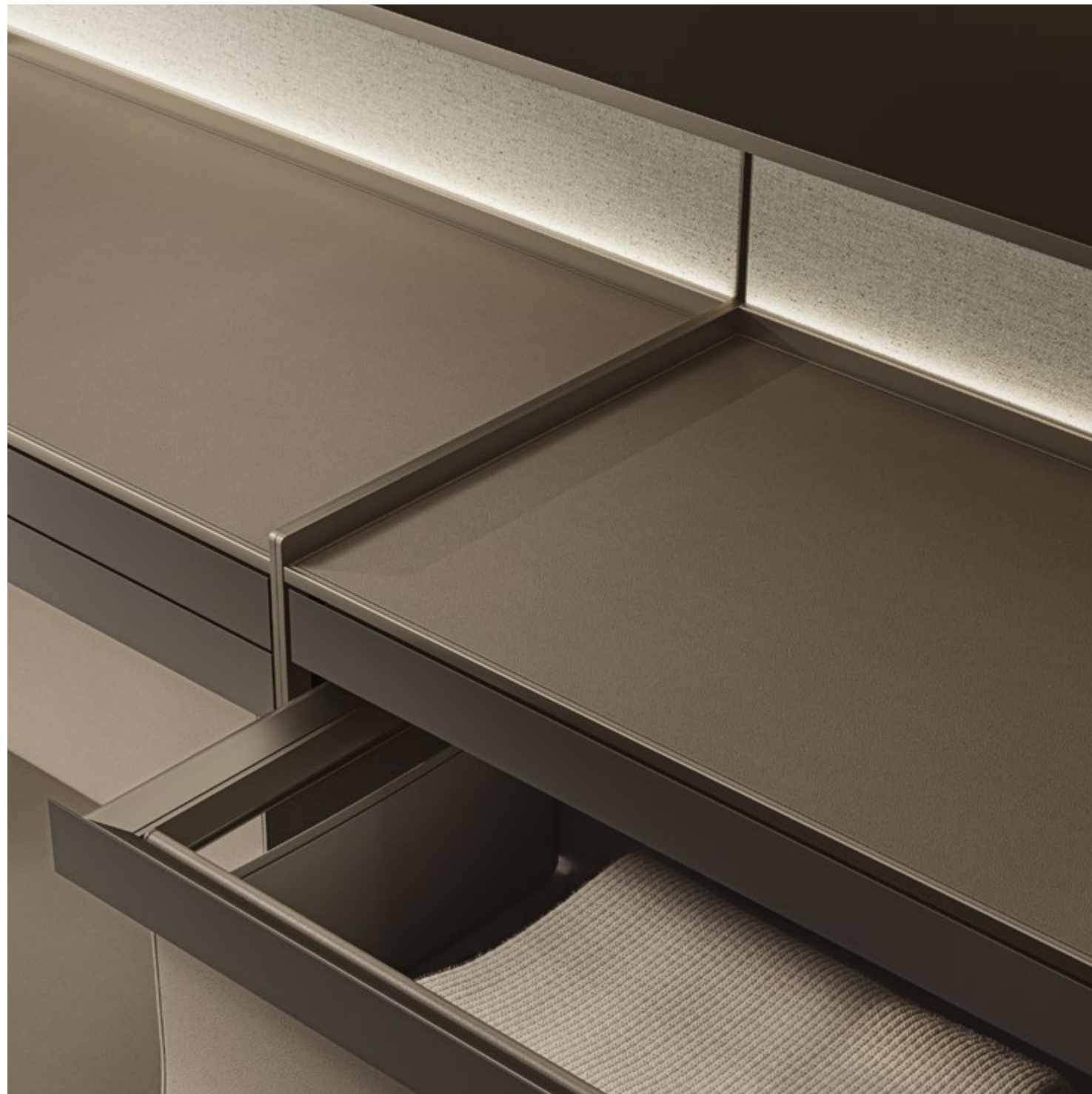



Structure and lacquered shelves: 303 bronzo
Nomad fabric panels: T201 gobi floor base
Suspended unit glass fronts: 136 bronzo opaco
Pullover holder: 19 rovere termotrattato
Big tray and floor base in synthetic leather: 154 argilla
Floor units with drawer: 136 bronzo opaco

In this photo
Wall partition system: Air system pure
Pouf: Tray
Carpet: Kita



Lacquered shelves: 303 bronzo
Clothes-hanger bar in satin stainless steel covered
with synthetic leather: 154 argilla
Aluminium dimmable led-spotlight

EN Hedon is set apart by its modularity, with panels available in three standard widths, as well as heights that can be customised to the millimetre, up to a maximum of 3894 mm. Fully capable of combining functionality and sophisticated design, the system offers new interpretations of space in which refined materials and innovative solutions breathe life into a custom-made, elegant and harmonious environment.

IT Hedon si distingue per la sua modularità, con pannelli disponibili in tre larghezze standard e su misura, con altezza personalizzabile al millimetro, fino a un massimo di 3894 mm. Un sistema in grado di combinare funzionalità e design sofisticato, offrendo nuove interpretazioni dello spazio in cui materiali pregiati e soluzioni innovative danno vita a un ambiente su misura, elegante e armonioso.

DE Hedon zeichnet sich durch hohe Modularität aus: Paneele sind in drei Standardbreiten sowie maßgefertigt erhältlich, mit millimetergenau anpassbarer Höhe bis zu 3894 mm. Ein System, das Funktionalität und anspruchsvolles Design verbindet und neue Rauminterpretationen ermöglicht, in denen hochwertige Materialien und innovative Lösungen ein maßgefertigtes, elegantes und harmonisches Ambiente formen.

FR Hedon se distingue par sa modularité, avec des panneaux disponibles en trois largeurs standard et sur mesure, et des hauteurs personnalisables au millimètre près, jusqu'à un maximum de 3894 mm. Ce système allie fonctionnalité et design sophistiqué, en offrant de nouvelles interprétations de l'espace où matériaux nobles et solutions innovantes créent un environnement sur mesure, élégant et harmonieux.

ES Hedon destaca por su modularidad, con paneles disponibles en tres anchos estándar y a medida, con alturas personalizables al milímetro, hasta un máximo de 3894 mm. Este sistema combina funcionalidad y diseño sofisticado, ofreciendo nuevas interpretaciones del espacio en las que la combinación de materiales nobles y soluciones innovadoras crea un ambiente personalizado, elegante y armonioso.

RU Система Hedon отличается исключительной модульностью: панели представлены в трех вариантах ширины или выполняются на заказ, а их высота подбирается с точностью до миллиметра (вплоть до 3894 мм) Эта система представляет собой идеальный синтез функциональности и высококлассного дизайна. Благодаря премиальным материалам и инновационным технологиям она позволяет создать изысканное гармоничное пространство, полностью адаптированное под запросы конкретного заказчика.

汉语 Hedon 的独特之处在于模块化设计，面板提供三种标准宽度或定制宽度，高度则可精确至毫米，最高可达 3894 毫米。本系统将功能性与考究设计精妙结合，为空间带来崭新诠释形式，所选用的上乘材质融萃创新解决方案，构筑出量身定制、精雅和谐的空间环境。



Structure and lacquered shelves: 303 bronzo
Nomad fabric panels: T201 gobi floor base
Suspended unit top in synthetic leather: 154 argilla
Wooden pullover holder: 19 rovere termotrattato
Glass drawer fronts: 136 bronzo opaco

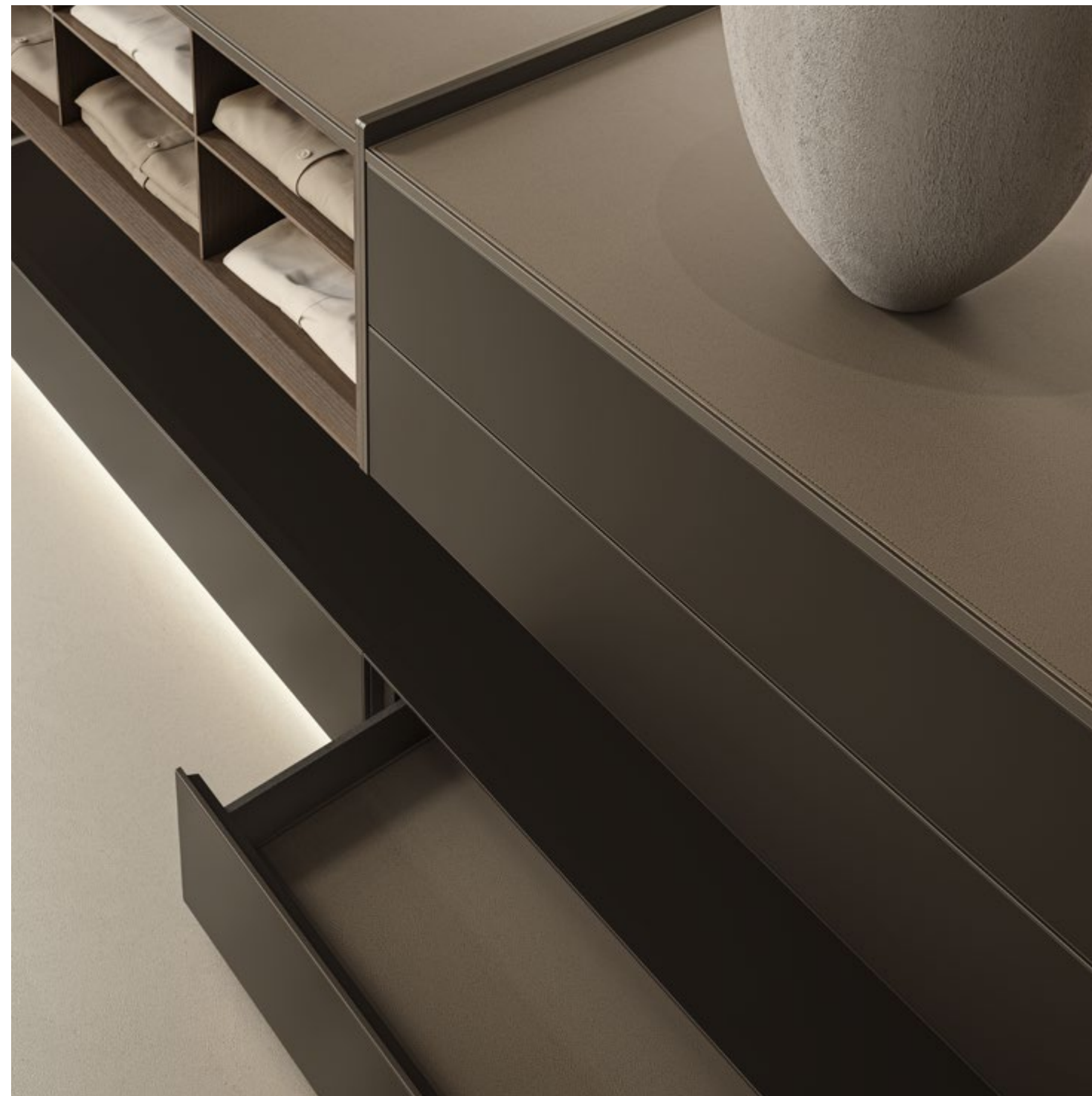

Structure: 303 bronzo
Suspended unit top and internal mat
in synthetic leather: 154 argilla
Wooden suspended pullover holder: 19 rovere termotrattato
Glass drawer fronts: 136 bronzo opaco
Melamine drawer interior: UB09 cuoio brown



Structure: 83 piombo
Rafia panels: T115 stone
Wooden shelves: 19 rovere termotrattato
Clothes-hanger bar, shoe shelves and floor base
in synthetic leather: 154 argilla
Suspended units top and drawer front: 67 riflettente chiaro
Wooden drawer fronts: 20 rovere termotrattato sahara
Glass fronts pull-out accessories: 127 piombo opaco

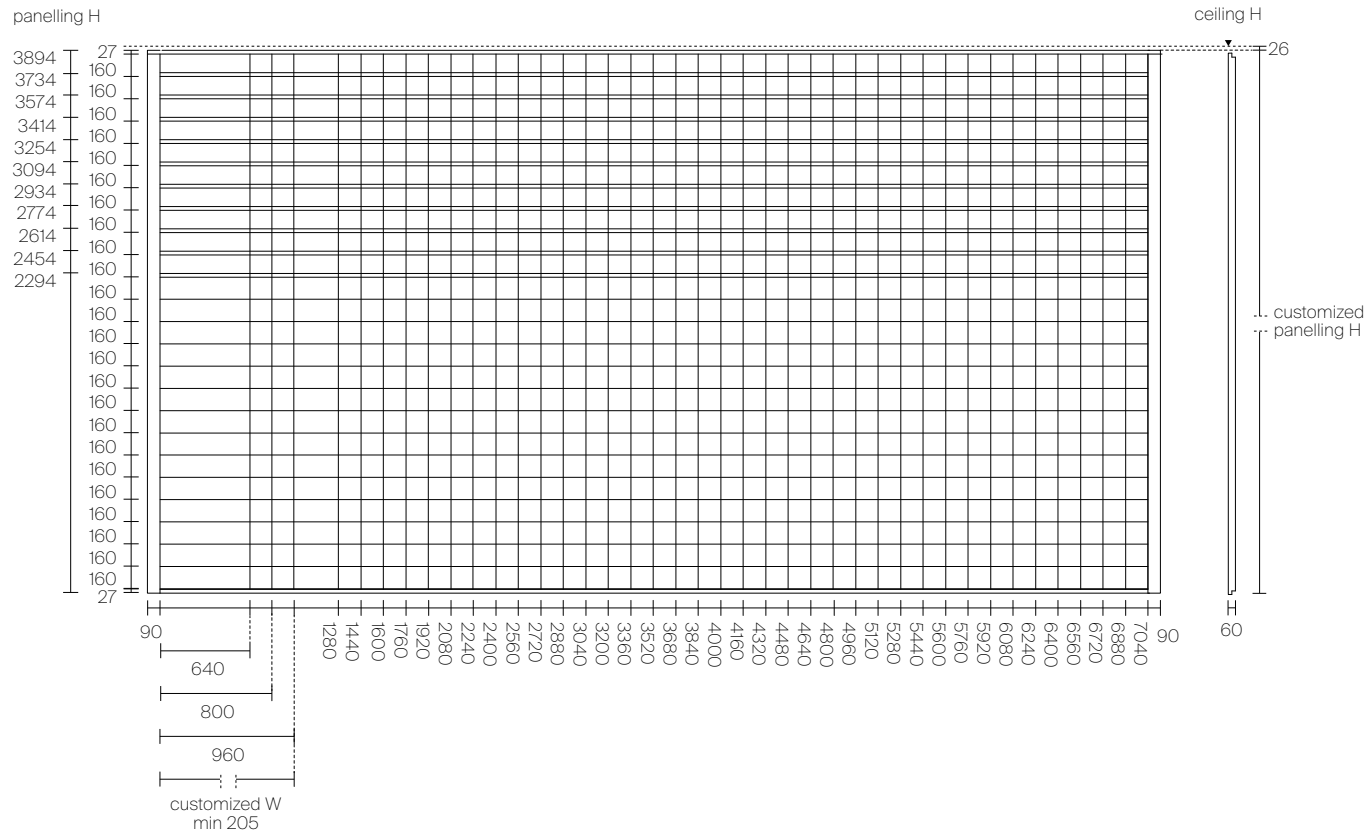

TECHNICAL DESCRIPTION

EN Hedon compositions stand out for their modularity: the panels are available in three standard widths or custom sizes, while the height can be customized up to 3894 mm. The accessories can be freely positioned thanks to an electrified rack system, allowing the layout to adapt to different space organization needs. The range of accessories includes linear or inclined shelves, hanging rails, trouser racks, and drawer units.

IT Le composizioni Hedon si distinguono per la loro modularità: i pannelli sono disponibili in tre larghezze standard o su misura, mentre l'altezza è personalizzabile fino a 3894 mm. Gli accessori vengono posizionati liberamente grazie a un sistema a cremagliera elettrificata, per adattarsi alle esigenze di organizzazione dello spazio. La gamma di accessori comprende ripiani lineari o inclinati, aste portabiti, porta pantaloni e cassettiere.

DE Die Hedon-Kompositionen zeichnen sich durch ihre Modularität aus: Die Paneele sind in drei Standardbreiten oder als Maßanfertigung erhältlich, während die Höhe bis zu 3894 mm individuell angepasst werden kann. Das Zubehör lässt sich dank eines elektrifizierten Rasterstangensystems frei positionieren, um sich den Anforderungen an die Raumorganisation anzupassen. Das Zubehörsortiment umfasst lineare oder geneigte Fachböden, Kleiderstangen, Hosenhalter und Schubladenelemente.

FR Les compositions Hedon se distinguent par leur modularité: les panneaux sont disponibles en trois largeurs standard ou sur mesure, alors que la hauteur est personnalisable jusqu'à 3894 mm. Les accessoires peuvent être positionnés librement grâce à un système à crémaillère électrifiée, afin de s'adapter aux besoins d'organisation de l'espace. La gamme d'accessoires comprend des étagères linéaires ou inclinées, des tringles porte-vêtements, des porte-pantalons et des blocs tiroirs.

ES Las composiciones Hedon se distinguen por su modularidad: los paneles están disponibles en tres anchuras estándar o a medida, mientras que la altura puede personalizarse hasta 3894 mm. Los accesorios pueden colocarse libremente gracias a un sistema de cremallera electrificado, para adaptarse a las necesidades de organización del espacio. La gama de accesorios incluye estantes lineales o inclinados, barras para colgar ropa, porta pantalones y cajoneras.

RU Композиции Hedon отличаются своей модульностью: панели доступны в трёх стандартных ширинах или изготавливаются на заказ, а высота может быть индивидуально настроена до 3894 мм. Аксессуары можно свободно размещать благодаря электрифицированной системе с зубчатой рейкой, что позволяет адаптировать решение к требованиям организации пространства. Ассортимент аксессуаров включает прямые или наклонные полки, штанги для одежды, держатели для брюк и выдвижные ящики.

汉语 Hedon 组合以其模块化设计而著称: 面板提供三种标准宽度或定制尺寸, 高度可个性化定制, 最高可达 3894 毫米。配件可通过电气化齿条系统自由安装, 以满足不同的空间收纳需求。配件系列包括直线或倾斜层板、挂衣杆、裤架和抽屉柜。

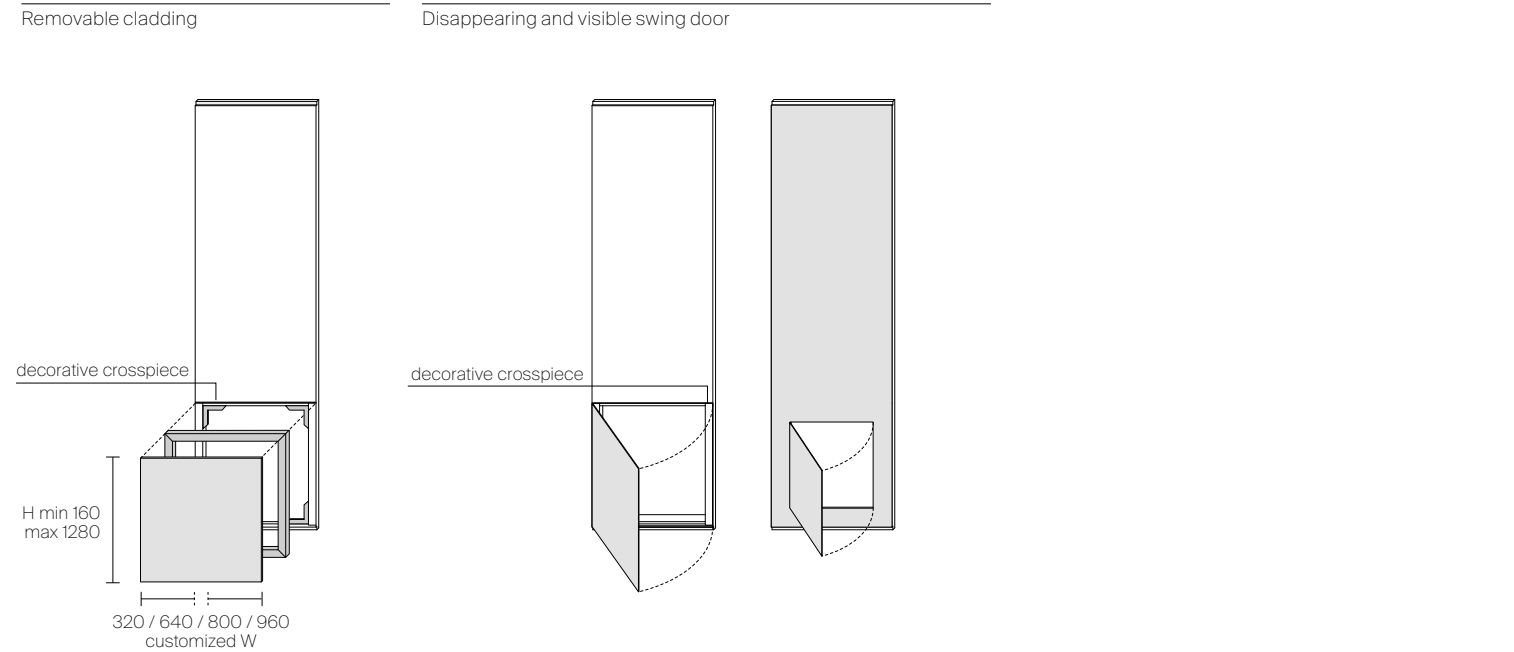
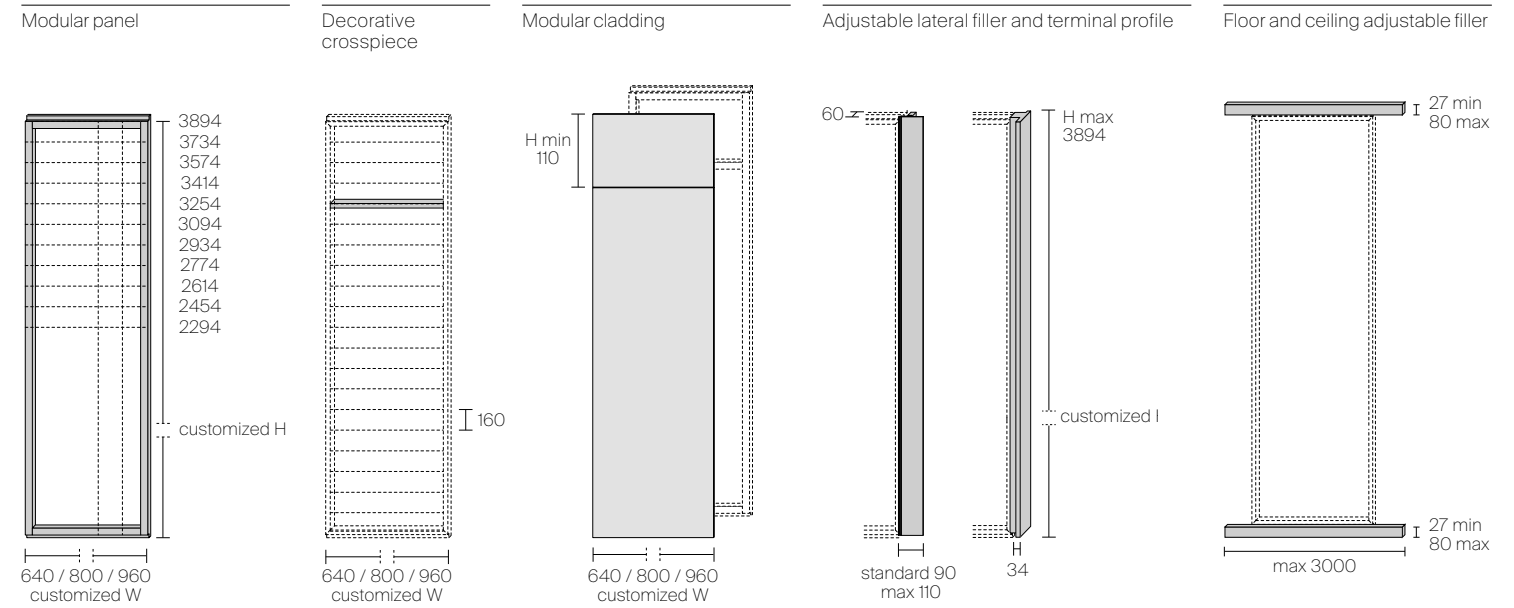
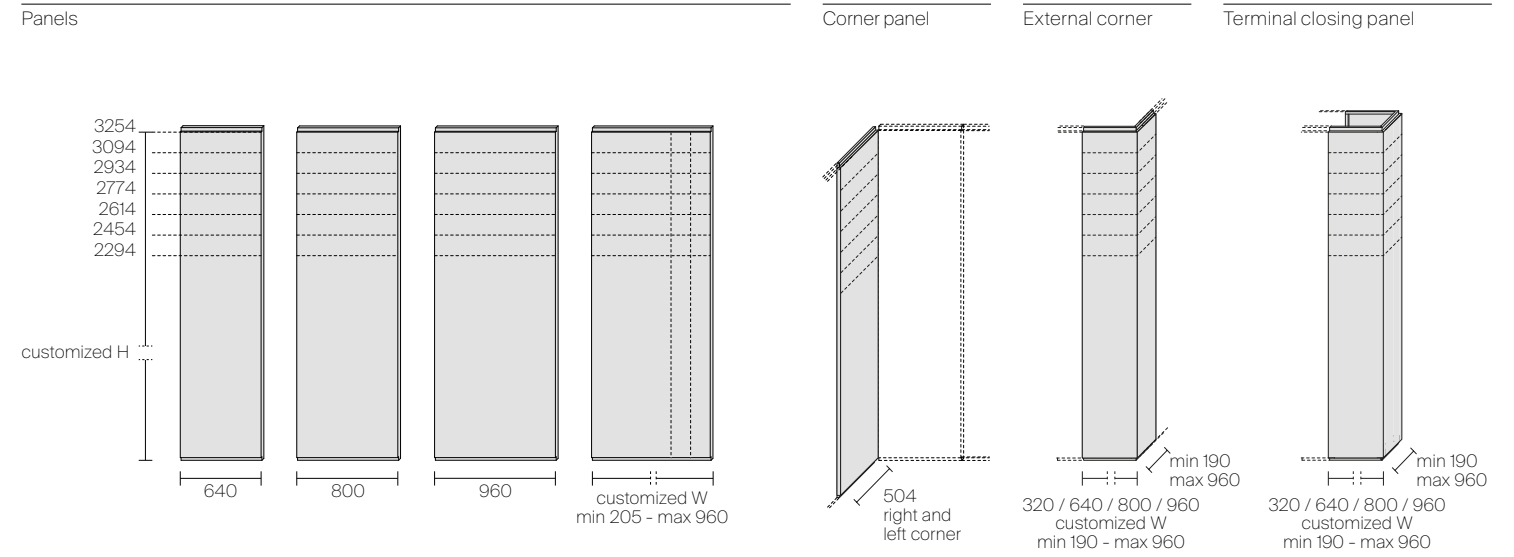

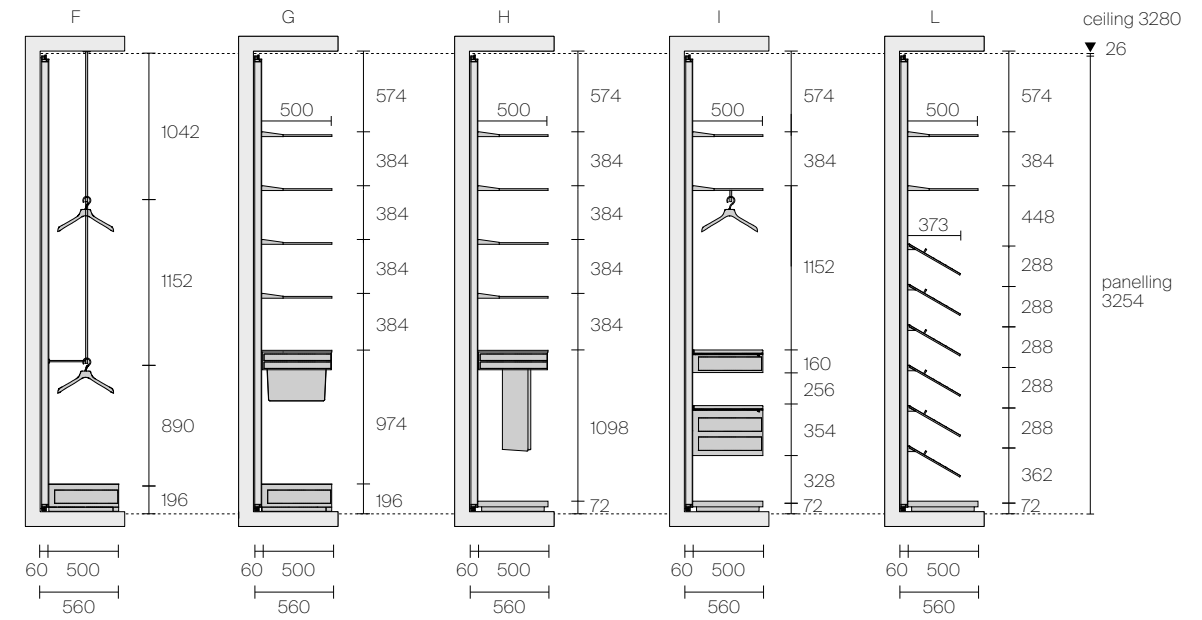
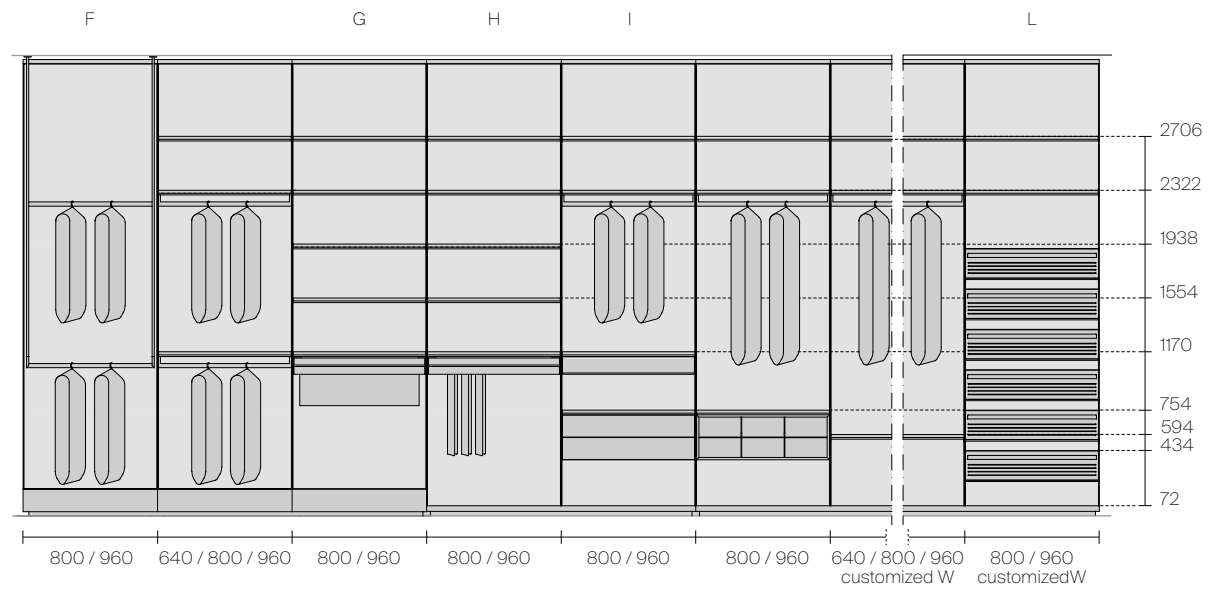
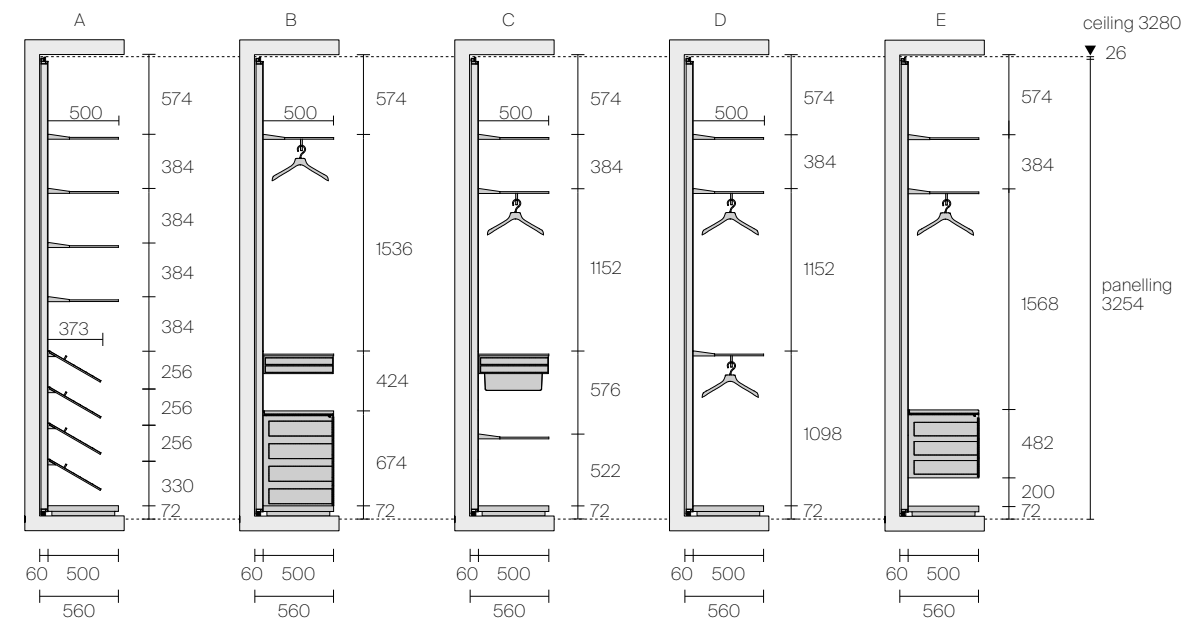
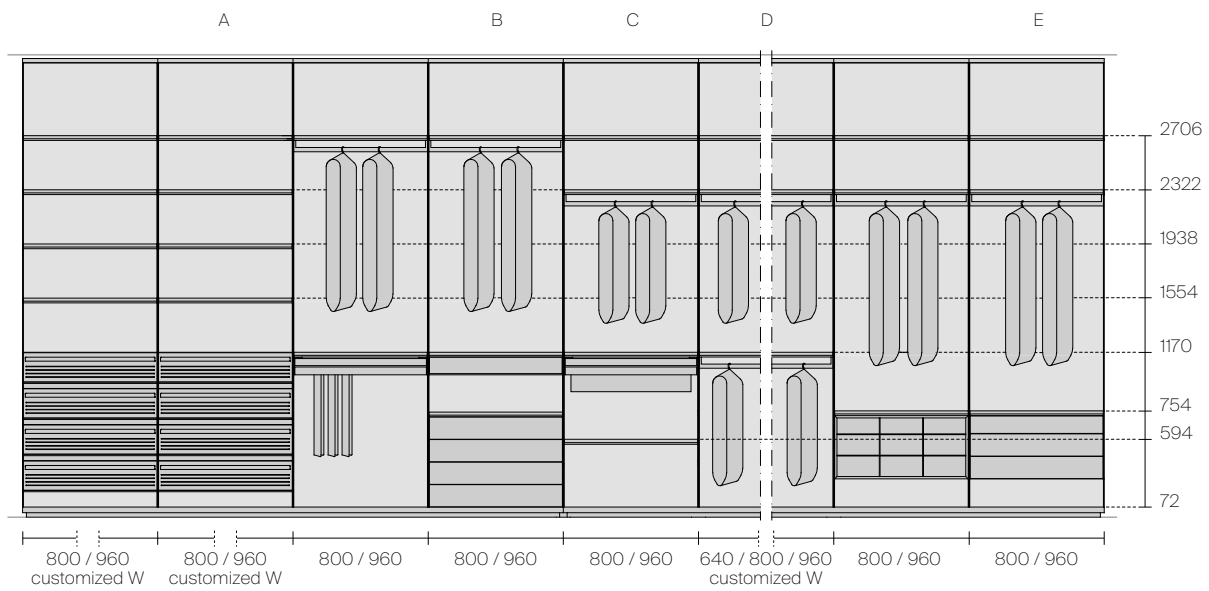

TECHNICAL DESCRIPTION

EN Hedon is a system designed to create fully customizable walk-in closets, adaptable to various configurations: linear, corner, external corner, C-shaped, or in niche. The flexible dimensional scheme ensures maximum design freedom, allowing the compositions to fit into any type of space.

IT Hedon è un sistema progettato per creare cabine armadio completamente personalizzabili, adattabili a diverse configurazioni: lineari, ad angolo, ad angolo esterno, a C o in nicchia. Lo schema dimensionale flessibile garantisce la massima libertà progettuale, consentendo di inserire le composizioni in qualsiasi tipo di spazio.

DE Hedon ist ein System zur Gestaltung vollständig individualisierbarer begehbare Kleiderschränke, das sich an verschiedene Konfigurationen anpassen lässt: linear, über Eck, Außenecke, C-förmig oder in einer Nische. Das flexible Maßsystem gewährleistet maximale Gestaltungsfreiheit und ermöglicht es, die Kompositionen in jede Art von Raum zu integrieren.

FR Hedon est un système conçu pour créer des dressings entièrement personnalisables, adaptables à différentes configurations : linéaires, d'angle, d'angle externe, en forme de C ou en niche. Le schéma dimensionnel flexible garantit une liberté de conception maximale, permettant d'intégrer les compositions dans tout type d'espace.

ES Hedon es un sistema diseñado para crear vestidores totalmente personalizables, adaptables a diferentes configuraciones: lineales, en esquina, en esquina exterior, en forma de C o en nicho. El esquema dimensional flexible garantiza la máxima libertad de diseño, permitiendo integrar las composiciones en cualquier tipo de espacio.

RU Hedon — это система, разработанная для создания полностью настраиваемых гардеробных, адаптируемых к различным конфигурациям: линейным, угловым, с внешним углом, C-образным или в нише. Гибкая размерная система обеспечивает максимальную свободу проектирования, позволяя интегрировать композиции в пространство любого типа.

汉语 Hedon 是一套用于打造完全可定制步入式衣帽间的系统，可适应多种布局形式：直线型、转角型、外转角型、C型或嵌入式。灵活的尺寸体系确保最大的设计自由度，使组合能够融入任何类型的空间。

Linear composition in niche with terminal profiles

Calculation of the customized panel width
 customized panel W = minimum opening W - 120 - 960 - 960 mm

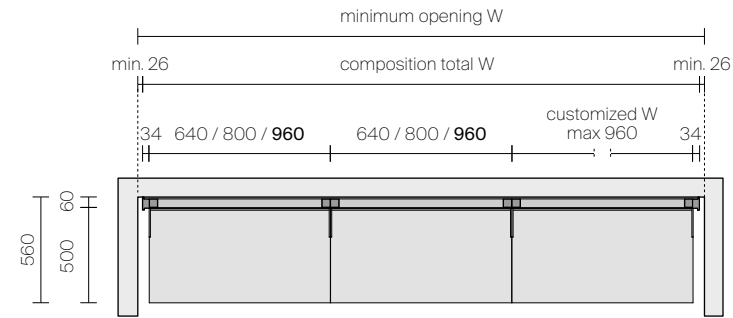

Linear composition in niche with adjustable lateral fillers

Calculation of the customized panel width
 customized panel W = minimum opening W - 180 - 960 - 960 mm

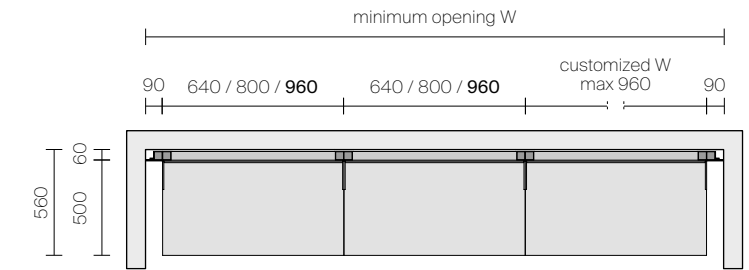

Linear composition with terminal profiles

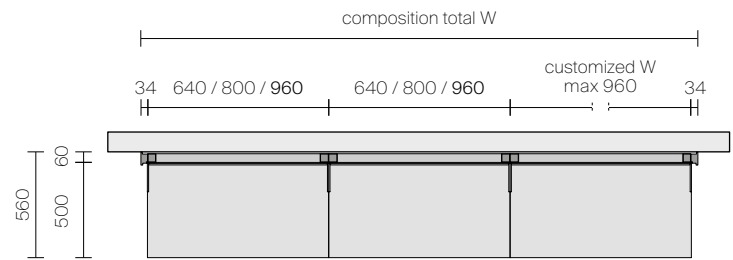

Linear composition in niche with W 504 corner panels used as sides

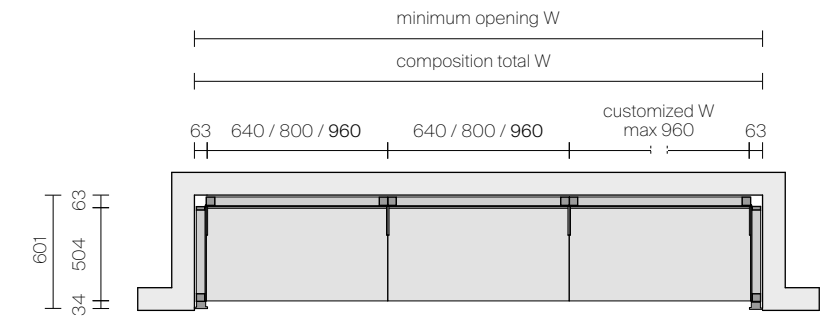

Linear composition with final panel and terminal profiles

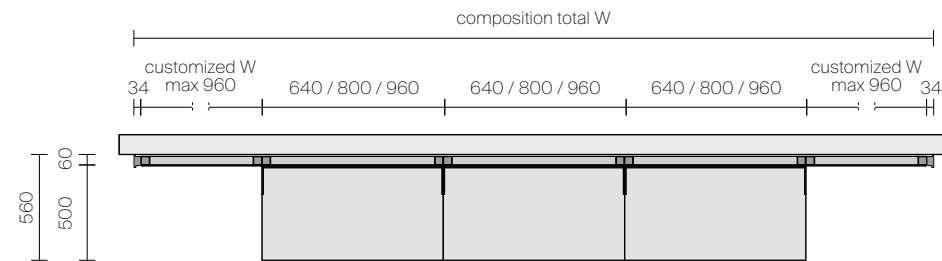

Linear composition in niche with corner panels with tailored width for cladding use

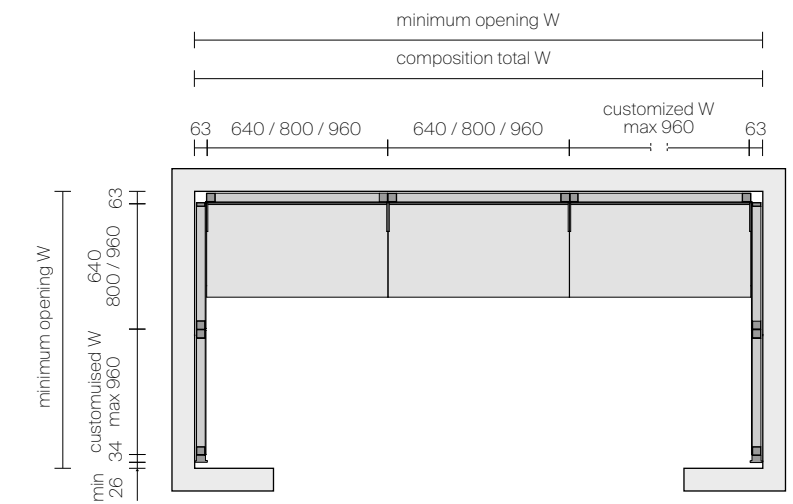

Corner composition with adjustable lateral fillers

Calculation of the customized panel width
 customized panel A W = minimum opening W - 153 - 960 - 960 mm
 customized panel B W = minimum opening W - 153 - 504 mm

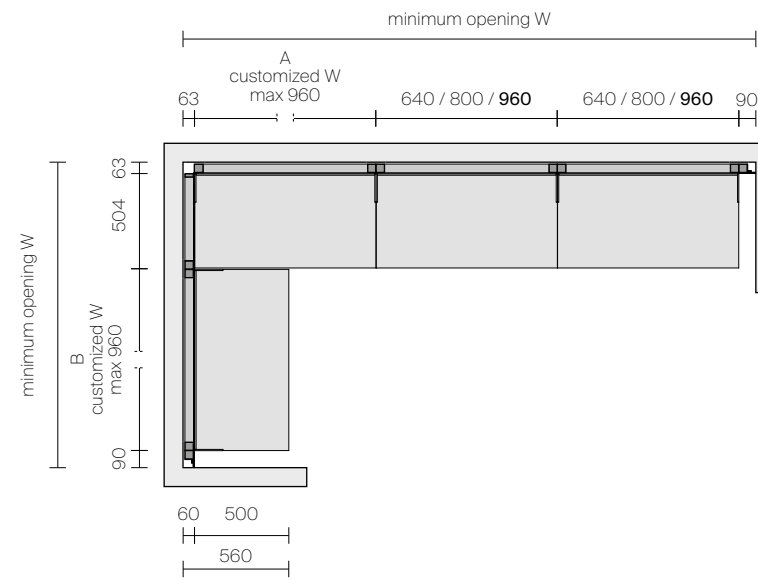

C composition with adjustable lateral fillers

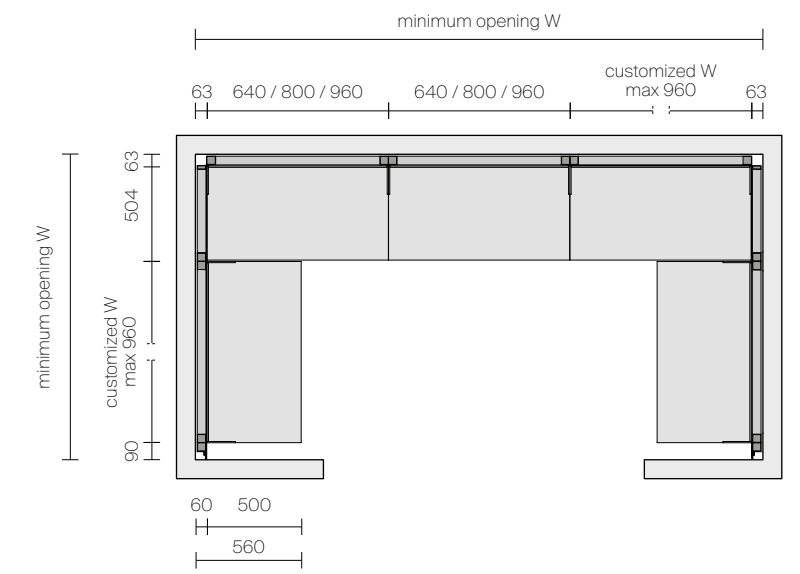

Symmetrical C shaped composition

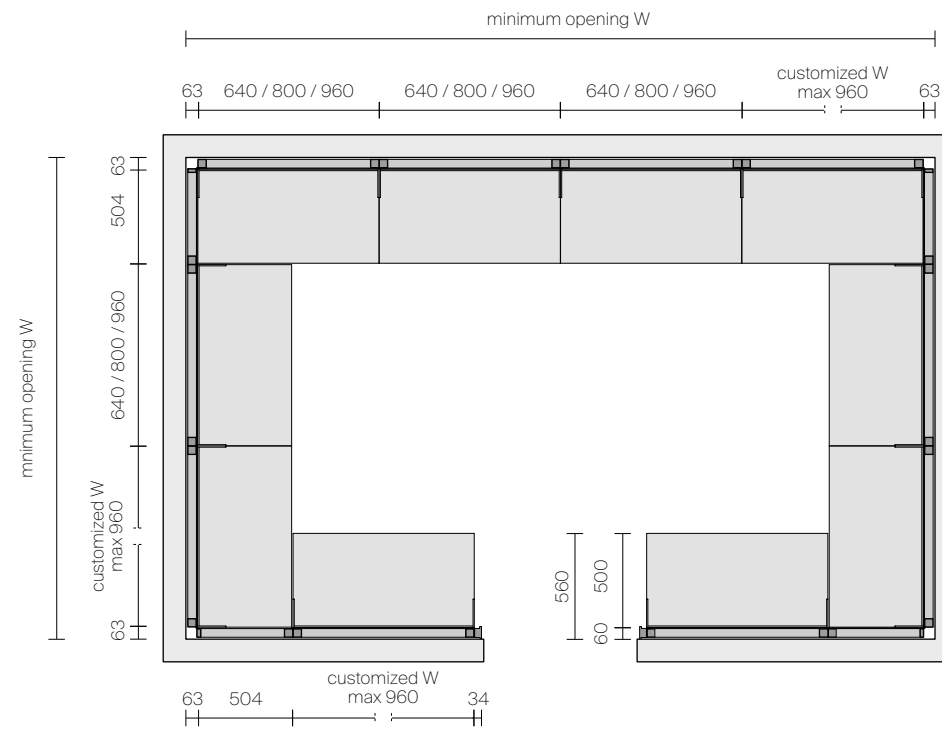

Asymmetrical C shaped composition

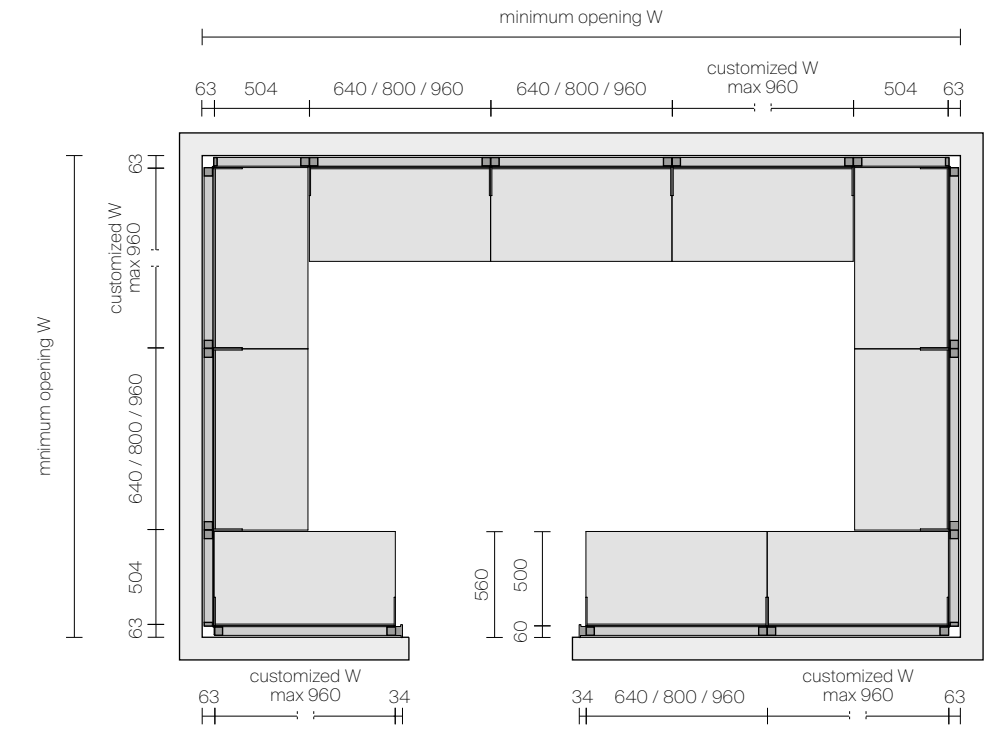

Composition with external corner panel

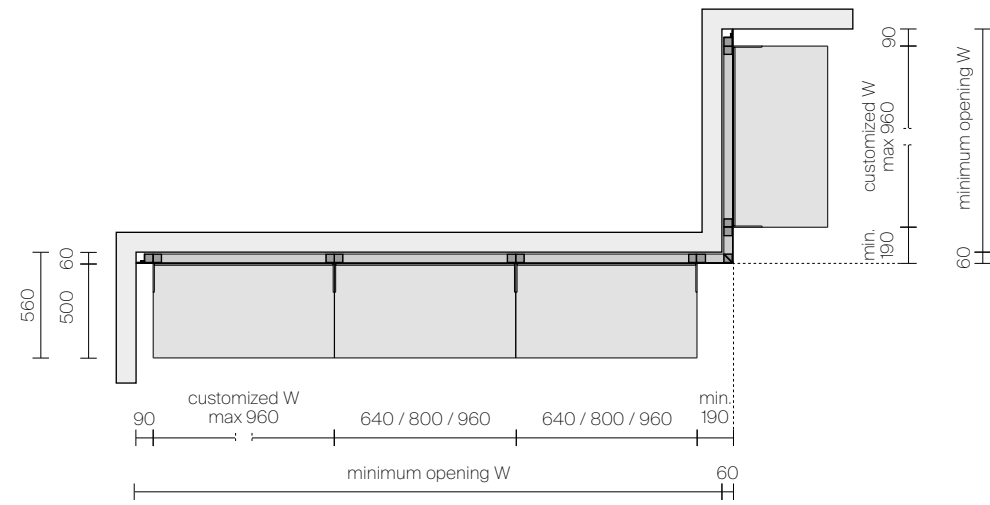

Composition with depth change

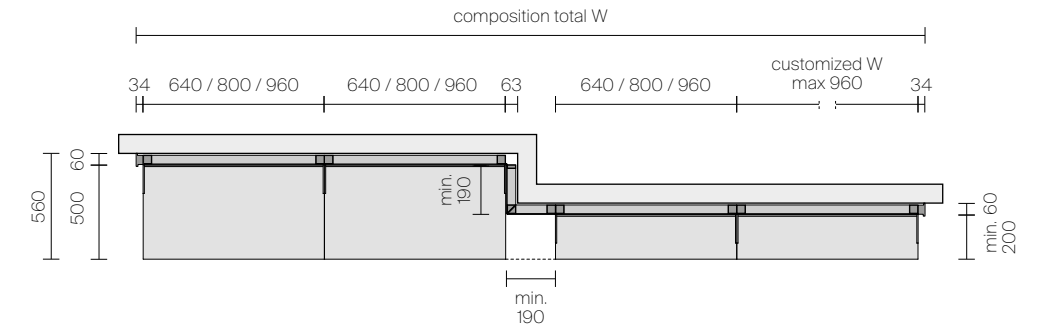

Composition with terminal closing panel

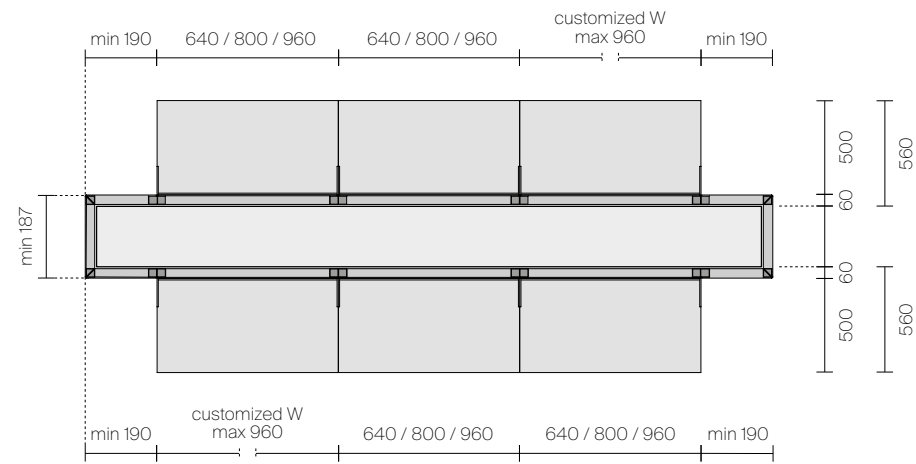

Composition covering a pilaster strip

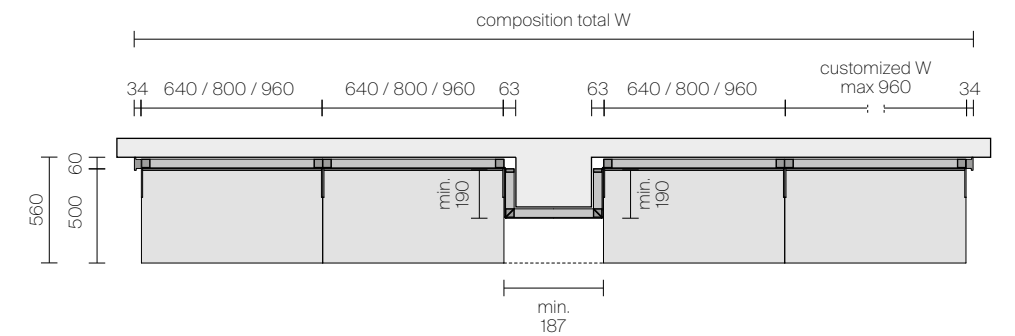

FLOOR BASE OPTIONS

Composition against the wall

Floor base and terminal profile



Floor base and final panel with terminal profile



Equipped floor unit and terminal profile



Equipped floor unit and final panel with terminal profile

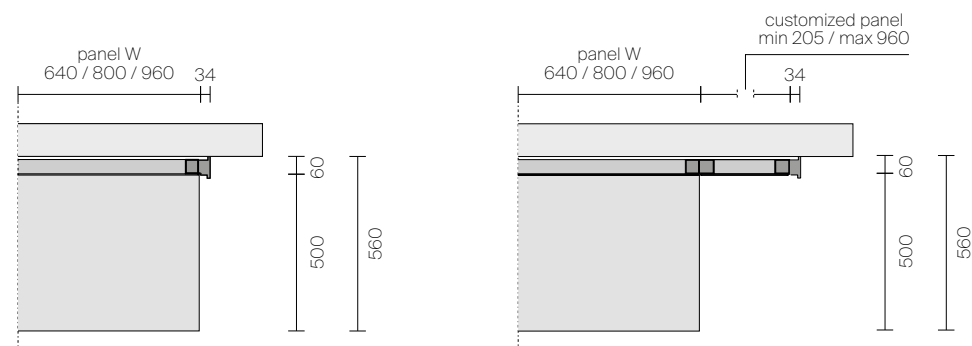

Composition in niche

Floor base and terminal profile



Floor base and adjustable lateral filler



Floor base and corner panel W 504



Equipped floor unit and terminal profile



Equipped floor unit and adjustable lateral filler



Equipped floor units and corner panel W 504

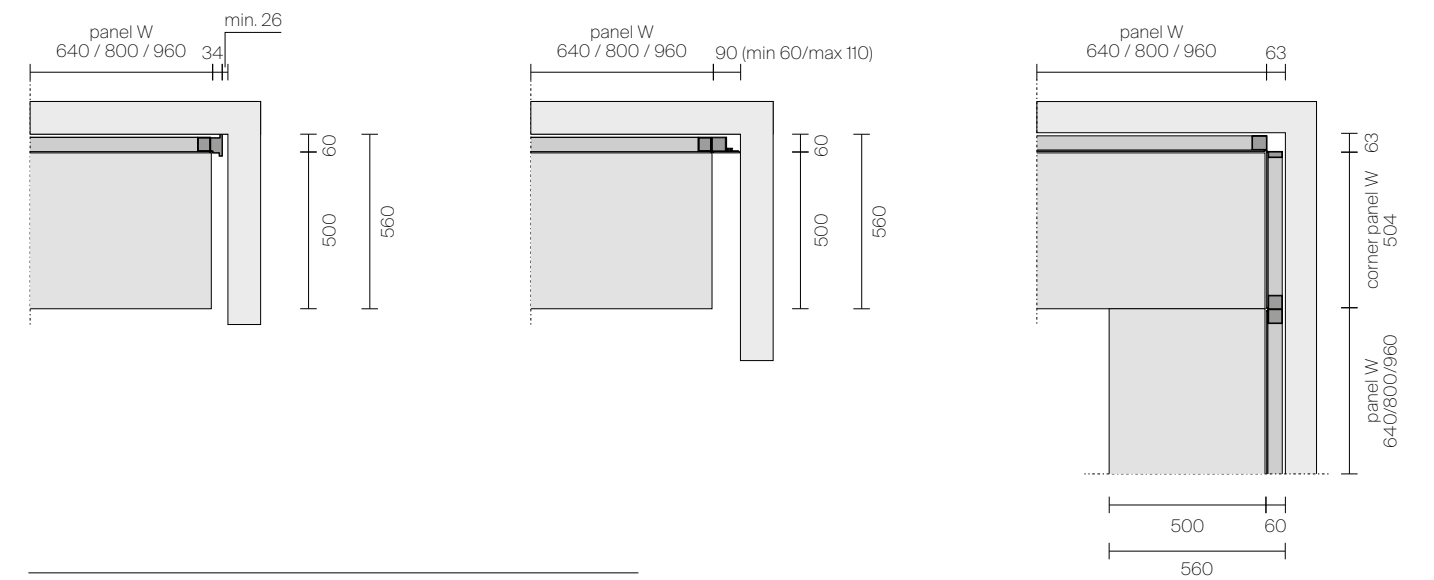

COMPONENTS

Linear floor unit with drawer

Corner floor unit with drawer

Top

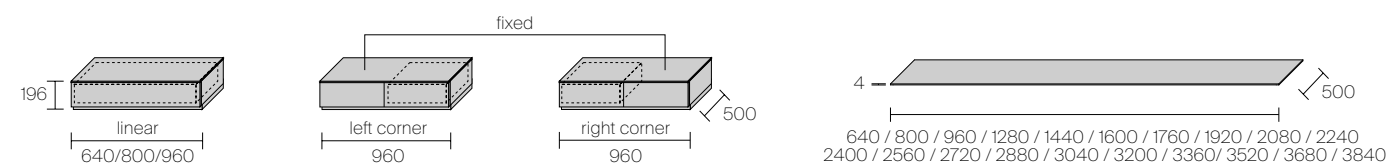

Floor base

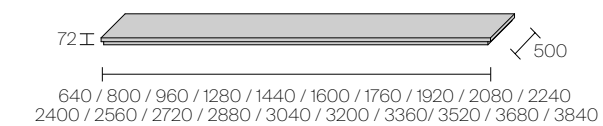



- 1. Lacquered shelf
- 2. Transparent glass shelf
- 3. Wooden shelf
- 4. Synthetic leather shelf
- 5. Melamine shelf

Lacquered shelf

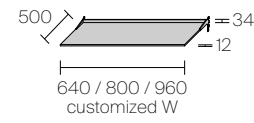

Back led lighting

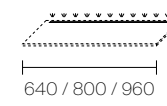

Front led spotlight

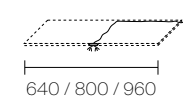

Back led lighting and front led spotlight

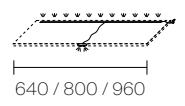

Transparent glass shelf

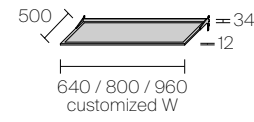

Back led lighting

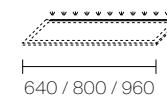

Front led lighting

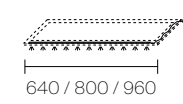

Back and front led lighting

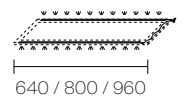

Wooden shelf

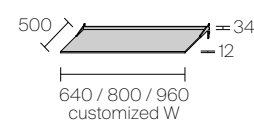

Back led lighting

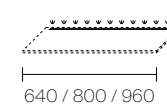

Front led spotlight

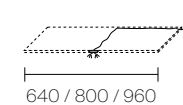

Back led lighting and front led spotlight

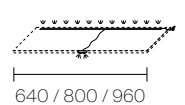

Synthetic leather shelf

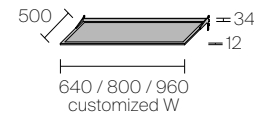

Back led lighting

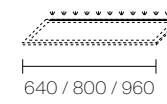

Front led lighting

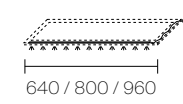

Back and front led lighting

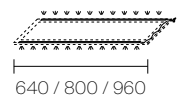

Melamine shelf

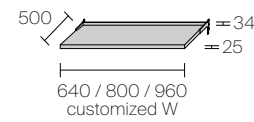

Back led lighting

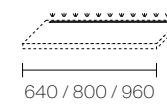

Front led spotlight

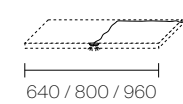

Back led lighting and front led spotlight

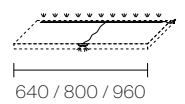



1



2

1. Transparent glass shelf with synthetic leather clothes-hanger bar. Back and front led lighting.
2. Lacquered shelf with satin nickel clothes-hanger bar. Back led lighting and front led spotlight.
3. Ceiling clothes-hanger bar in satin stainless steel and synthetic leather.
4. Ceiling clothes-hanger bar in satin stainless steel.



3



4

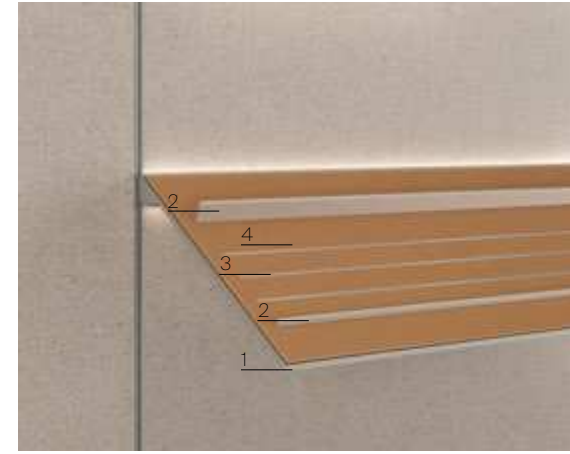

1. Lacquered structure in 304 platino
2. Aluminium profiles in 304 platino
3. Central profiles in satin nickel
4. Synthetic leather 160 miele

Inclined shoe shelf

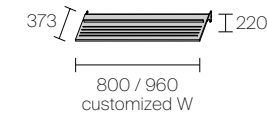

Upper back led lighting

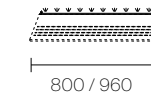

Lower back led lighting

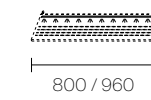

Upper and lower back led lighting

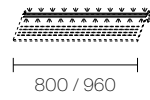

Clothes-hanger bar for shelf

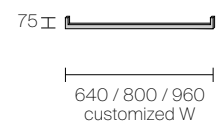

Ceiling clothes-hanger bar

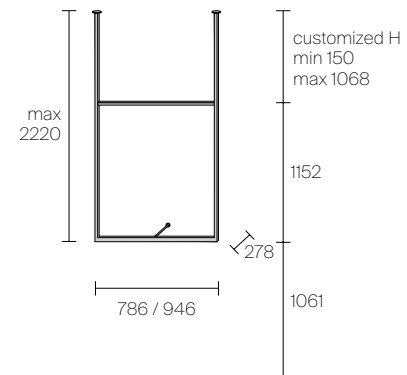

Clothes lift

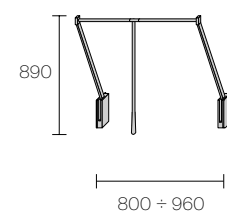



1



2

1. Suspended drawer unit with glass top and drawer front 67 riflettente chiaro, nomad fabric internal cladding T201 gobi.
2. Suspended drawer unit with top and drawer front in synthetic leather 160 miele.
3. Suspended drawer unit with glass top 137 platino opaco, wooden drawer fronts 701 rovere taiga.
4. Suspended drawer unit with top in synthetic leather 160 miele, glass drawer front 137 platino opaco.
5. Suspended drawer unit with glass top and drawer front 67 riflettente chiaro, nomad fabric internal cladding T201 gobi, wooden drawer fronts 701 rovere taiga.
6. Suspended drawer unit with top in synthetic leather 160 miele, glass drawer fronts 137 platino opaco.
7. Floor drawer unit with glass top 137 platino opaco, wooden drawer fronts 701 rovere taiga.
8. Drawer unit on wheels with top in synthetic leather 160 miele, glass drawer front 137 platino opaco.

Suspended drawer unit

1 drawer H 126 with internal cladding in fabric or synthetic leather

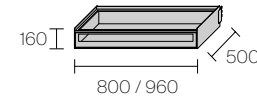

1 drawer H 126 with melamine internal

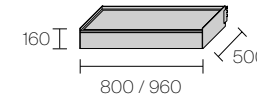

2 drawers H 160 with melamine internal

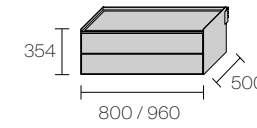

1 drawer H 320 with melamine internal

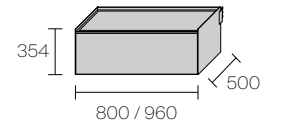

1 drawer H 126 with internal cladding in fabric or synthetic leather
1 drawer H 320 with melamine internal

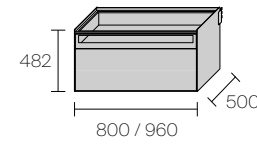

1 drawer H 160
1 drawer H 320 with melamine internal

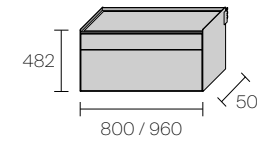

1 drawer H 126 with internal cladding in fabric or synthetic leather
2 drawers H 160 with melamine internal

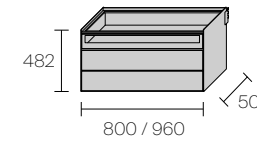

1 drawer H 126
2 drawers H 160 with melamine internal

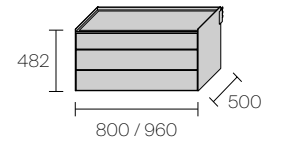

Floor drawer units

4 drawer H 160

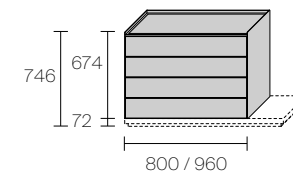

2 drawer H 160
1 drawer H 320

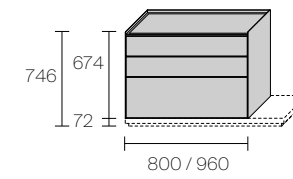

2 drawer H 320

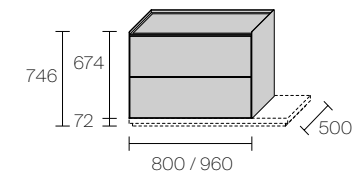

Drawer unit on wheels

4 drawer H 160

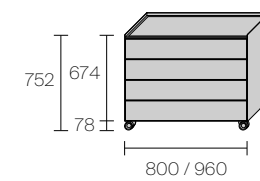

2 drawer H 160
1 drawer H 320

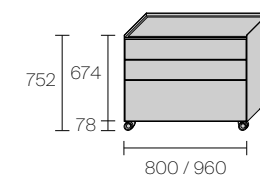

2 drawer H 320

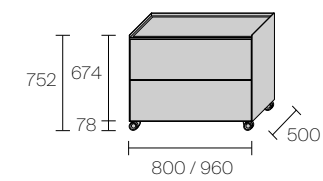

DRAWERS TECHNICAL DESCRIPTION



1. Drawer internal lining in fabric or synthetic leather
2. Drawer with melamine internal and synthetic leather mat

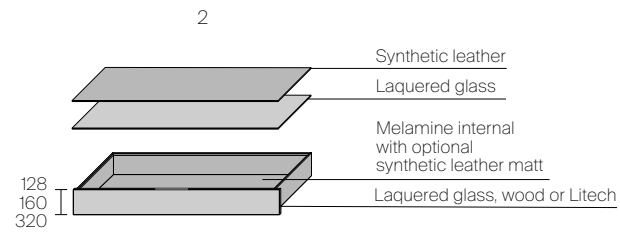
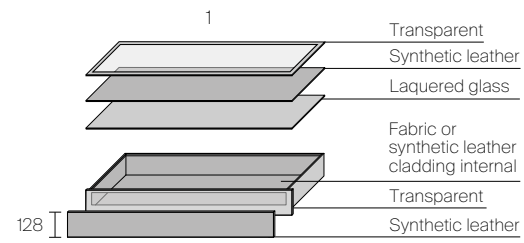

SUSPENDED PULLOVER HOLDER



1. Lacquered pullover holder with synthetic leather top
2. Wooden pullover holder with lacquered glass top

1

2

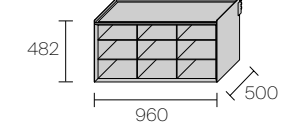
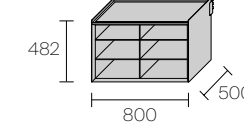
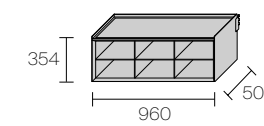
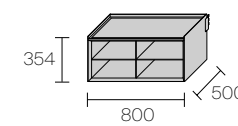

ACCESSORIES FOR DRAWERS



1. Proposal with 3 veneered organizers, 2 organizers with double partition and 2 concave boxes.
2. Proposal with 3 veneered organizers, 1 organizer with double partition, 2 box with jewels slots and 2 concave boxes.

1

2

Veneered organizer

Organizer with double partition in synthetic leather

Watch holder in synthetic leather

Box with concave box and jewels slots in synthetic leather

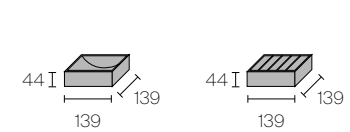
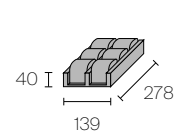
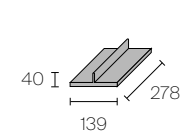
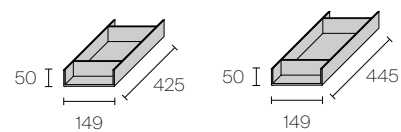



1



3



5



7

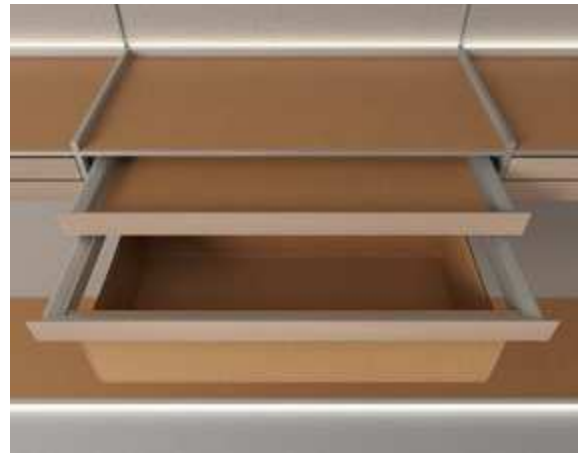

2



4



6

1. Synthetic leather pull-out tray and small tray with synthetic leather top. Wooden fronts in 711 rovere.
2. Synthetic leather pull-out tray and big tray with synthetic leather top. Wooden fronts in 711 rovere.
3. Synthetic leather double pull-out tray with 1 organizer with transparent top. Lacquered glass fronts.
4. Synthetic leather pull-out tray with 1 organizer and trousers rack with transparent top. Lacquered glass fronts.
5. Synthetic leather box
6. Synthetic leather tray
7. Synthetic leather cabinets on wheels

Synthetic leather double tray

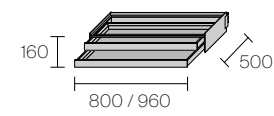

Synthetic leather double tray with 1 organizer

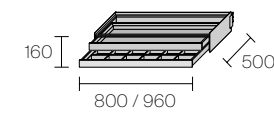

Synthetic leather tray and trousers rack

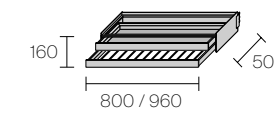

Pull-out tray and small tray in synthetic leather

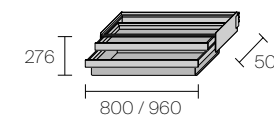

Pull-out tray and big tray in synthetic leather

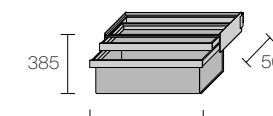

Synthetic leather double tray with 2 organizer

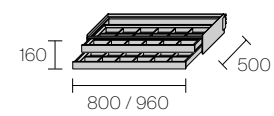

Synthetic leather double tray with 1 organizer

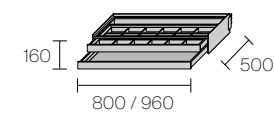

Synthetic leather tray with organizer and trousers rack

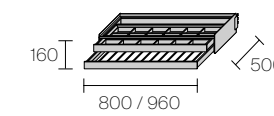

Synthetic leather tray with organizer and small tray

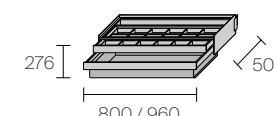

Synthetic leather tray with organizer and big tray

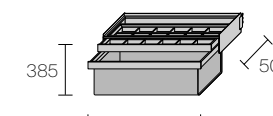

Synthetic leather cabinet on wheels, box and tray

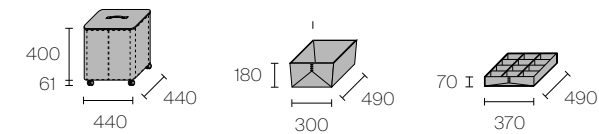

Wooden hanger



Hedon + Modulor

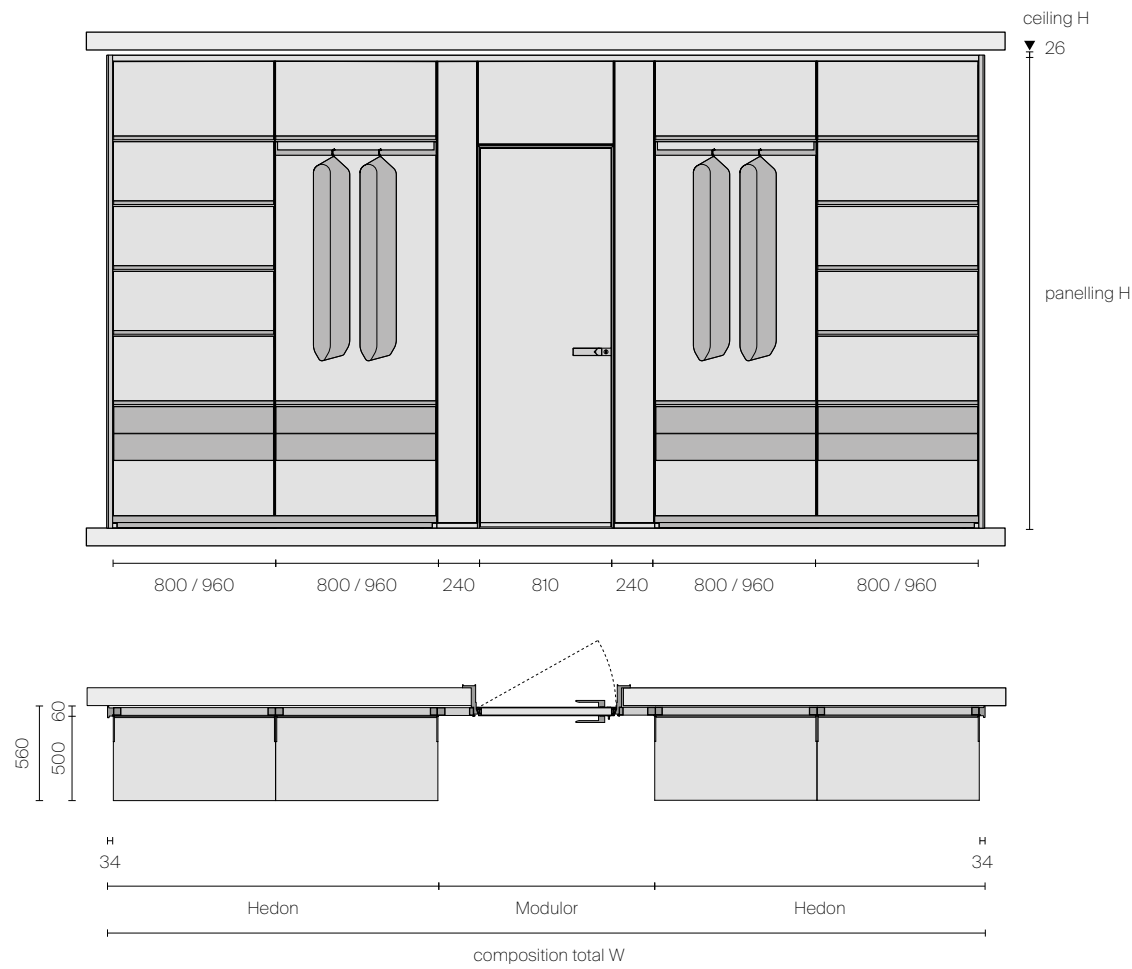

Hedon + Radius

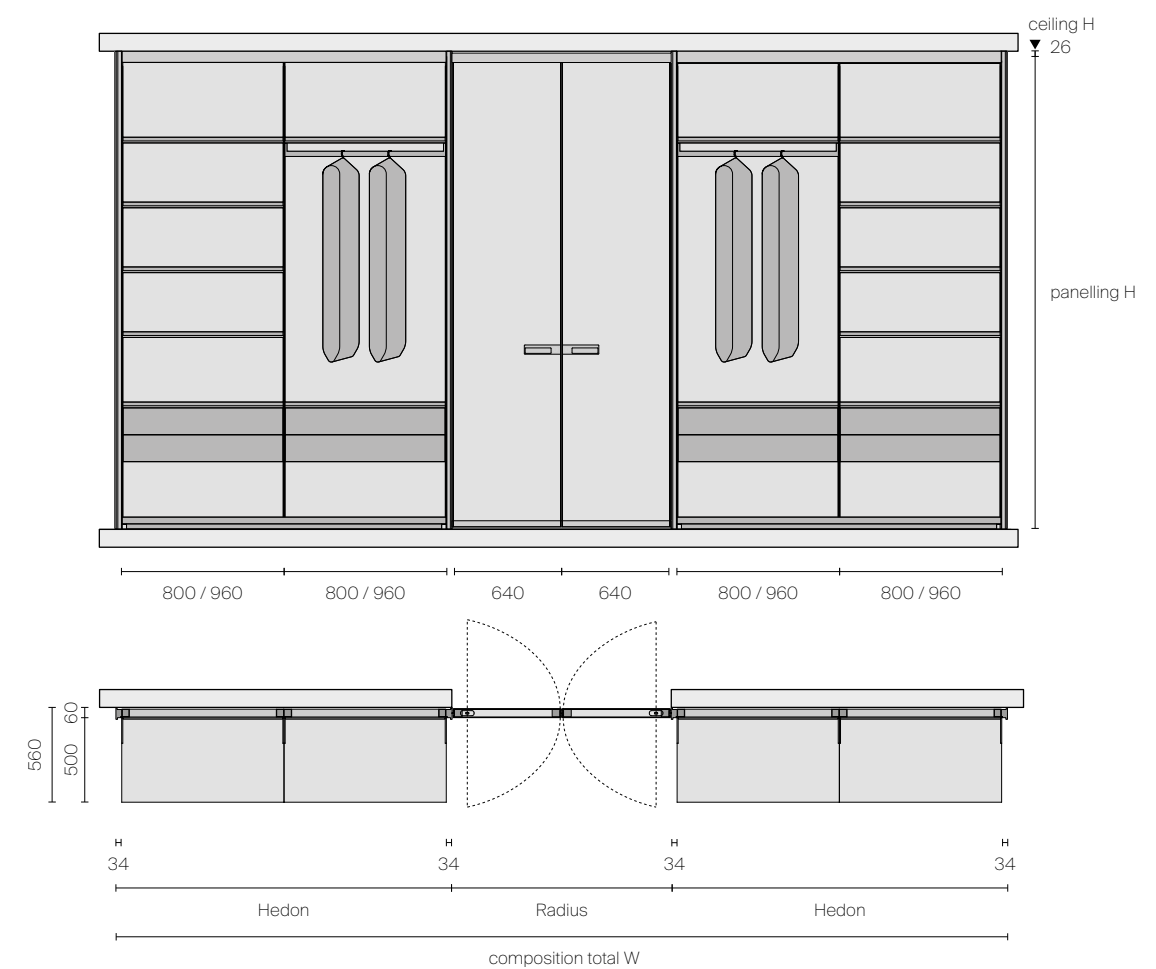

Hedon + Cover

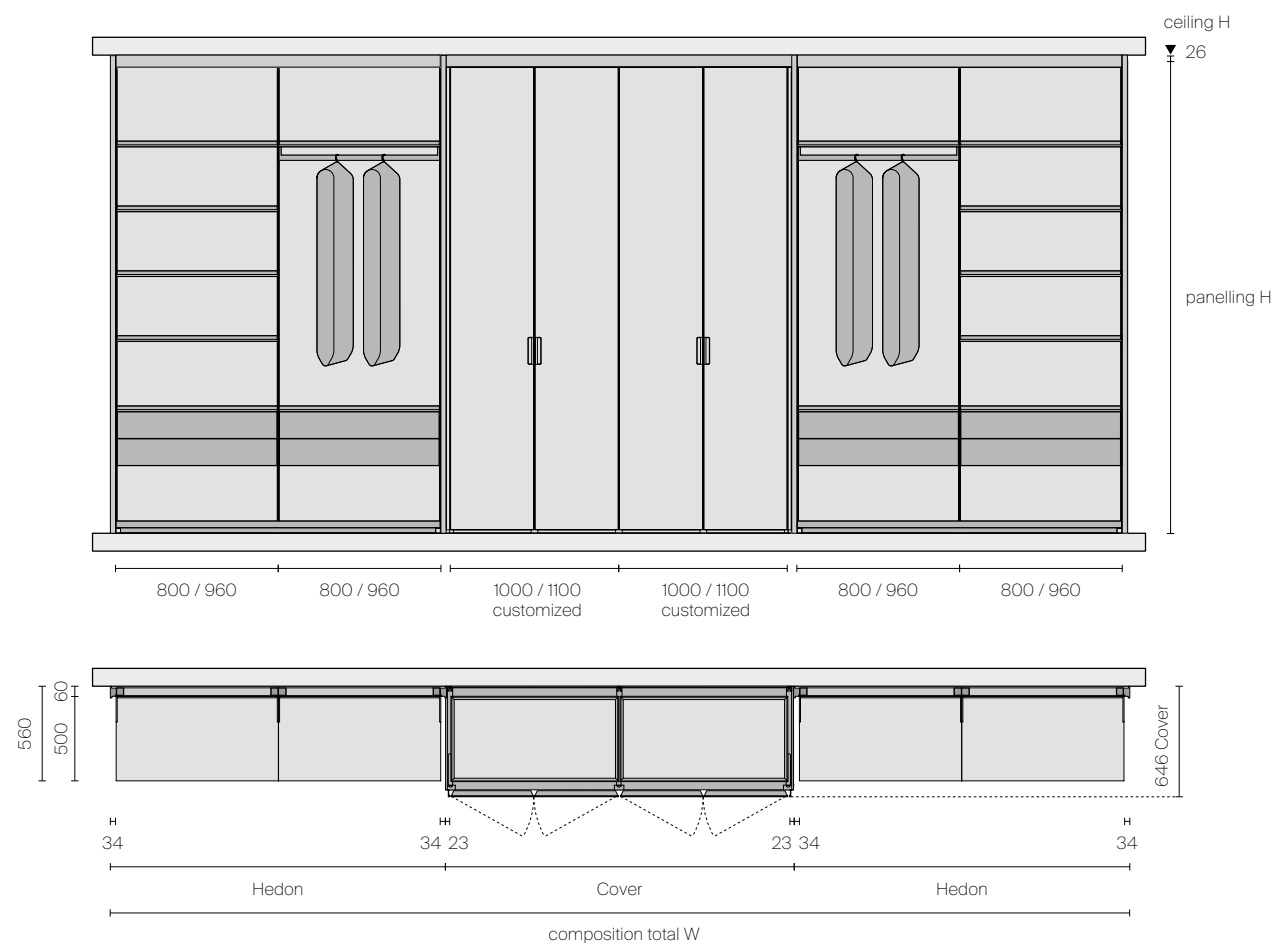

Hedon + Vanity



Side adjustable profile for ceiling or floor height change



Shaped panel for stairs



Detail of shaped panel for sloped ceiling

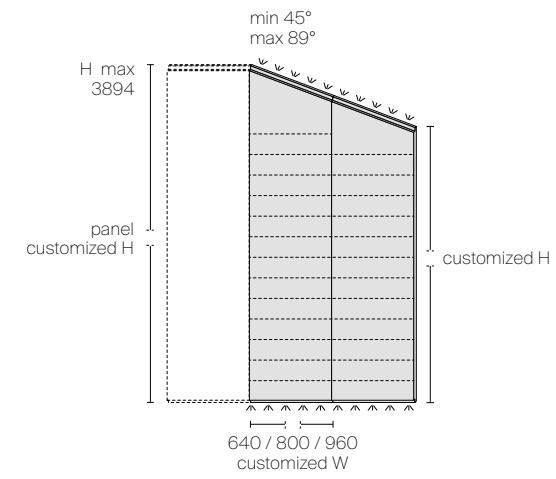
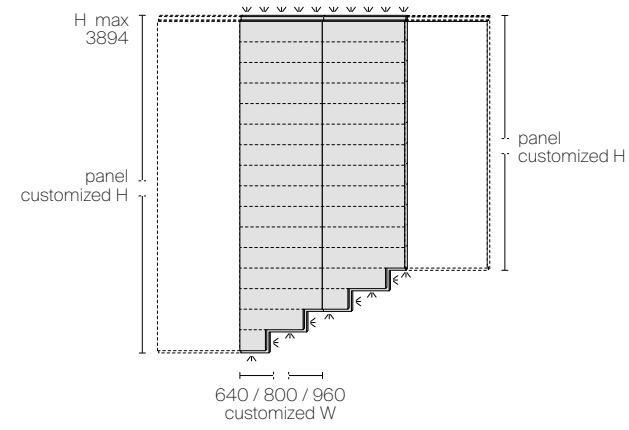
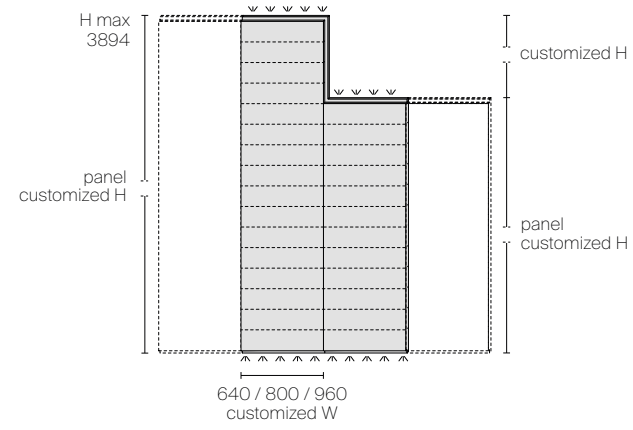

Removable cladding

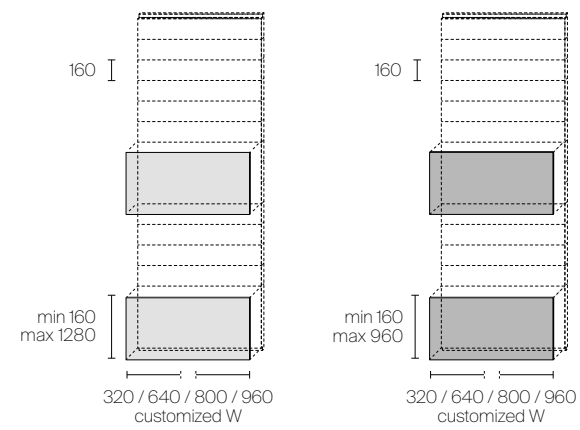

Opening swing door (push-pull opening)

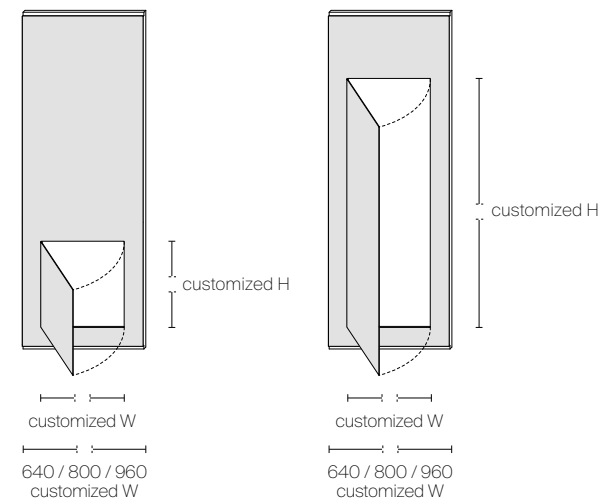
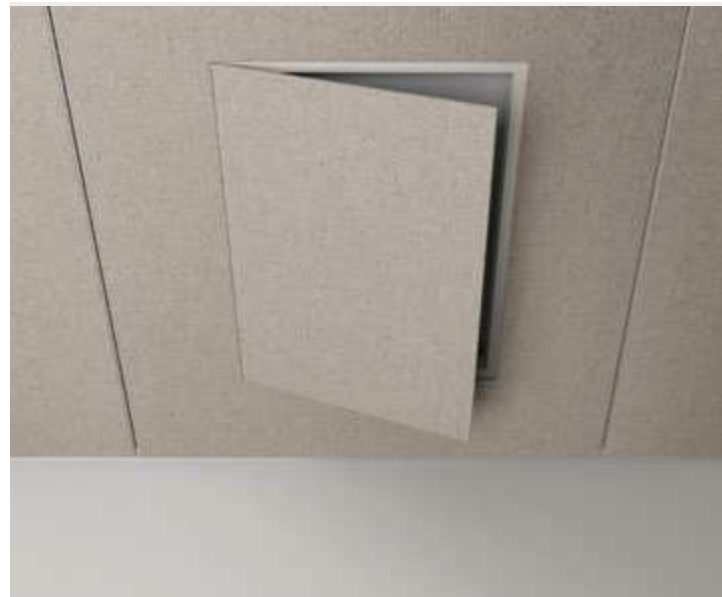

Opening swing door

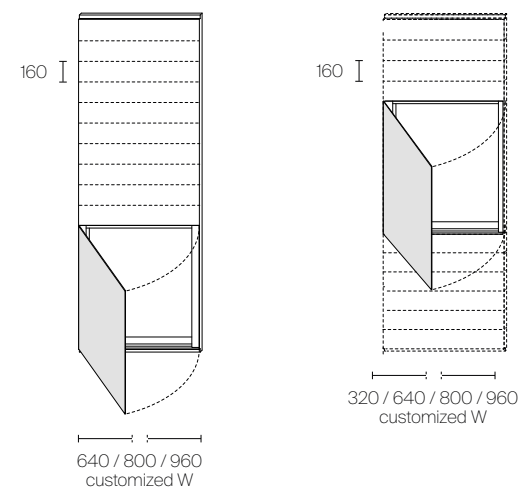

Concealed structure for suspended TV and extensible support for TV

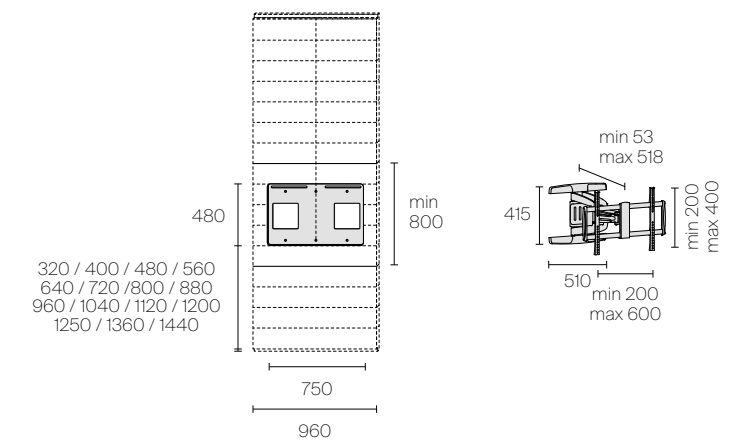

Customized cut-out for set-up of switches and electrical sockets

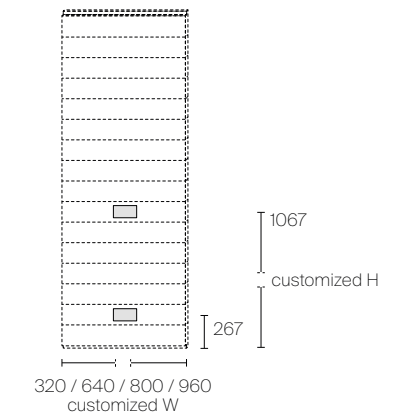
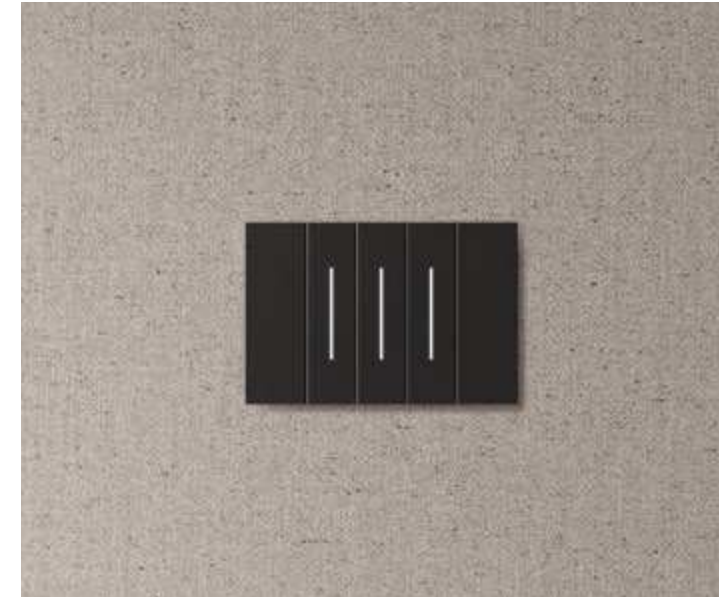

Cable duct

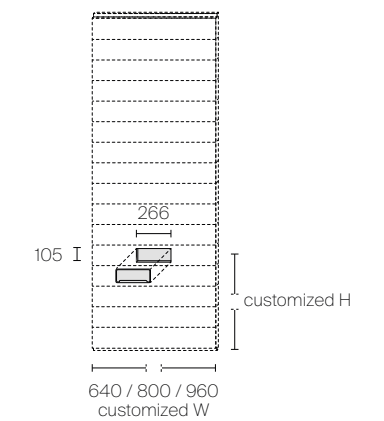
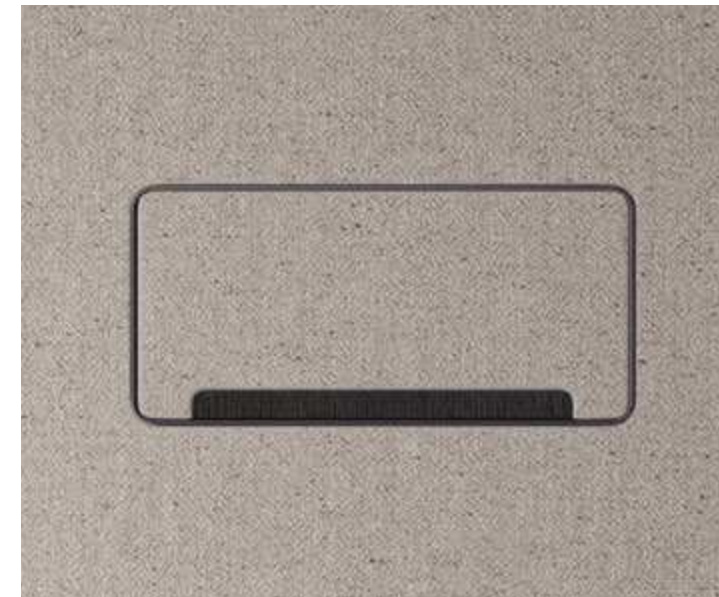



HEDON
Structure: 304 platino
Plain fabric panels: T224 shell
Melamine shelves: E001 rovere light
Drawer units top, clothes-hanger bar, big trays and floor units in synthetic leather: 157 arena
Glass unit fronts: 137 platino opaco
Wooden unit fronts: 701 rovere taiga

RADIUS
Structure: 304 platino
Handle: 304 platino, 137 platino opaco
Plain fabric cladding: T224 shell

Glossy glass



Matt glass



Sahara wood



Taiga wood

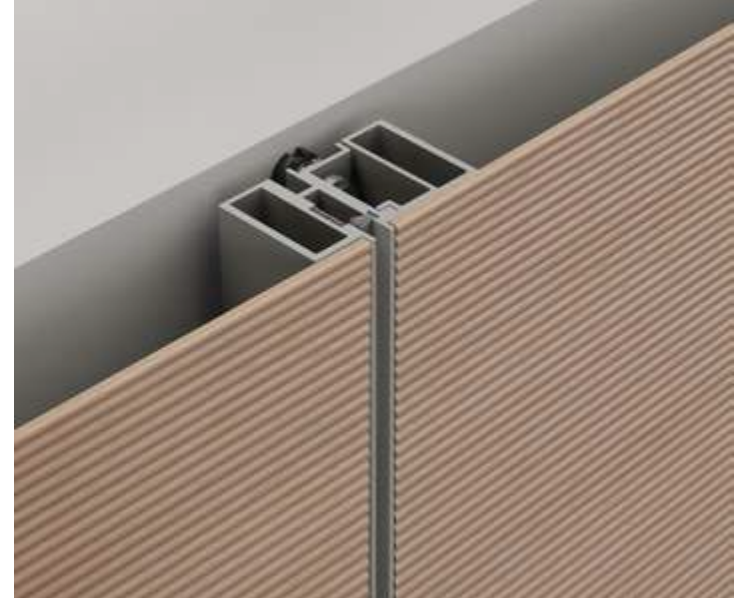

Sahara glass



Taiga glass



Rafia



Synthetic leather



Diamante glass



Litech



Tessuto



Tessuto Plain



Structure

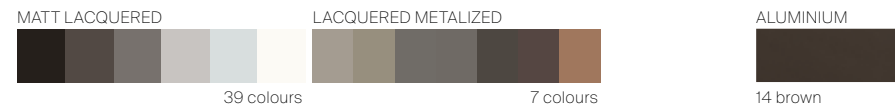

Floor base top

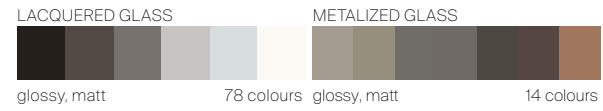

Panels cladding

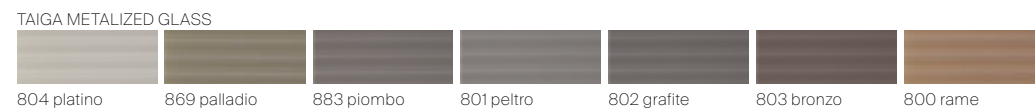
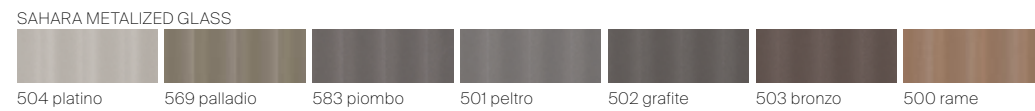
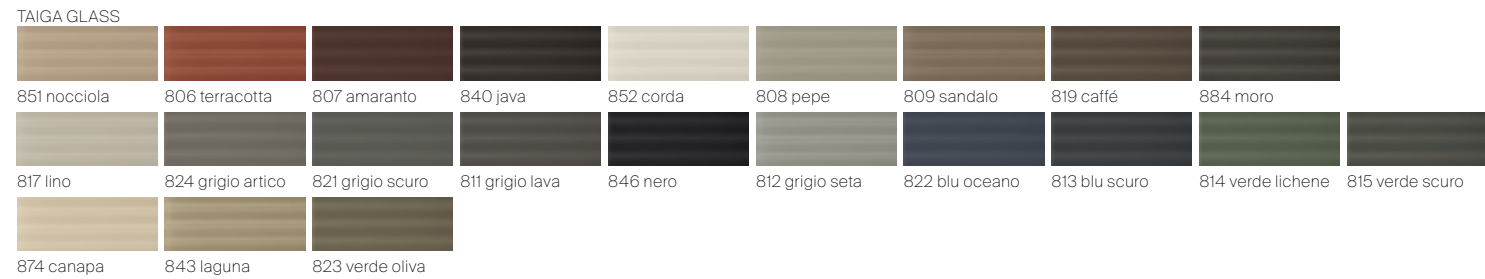
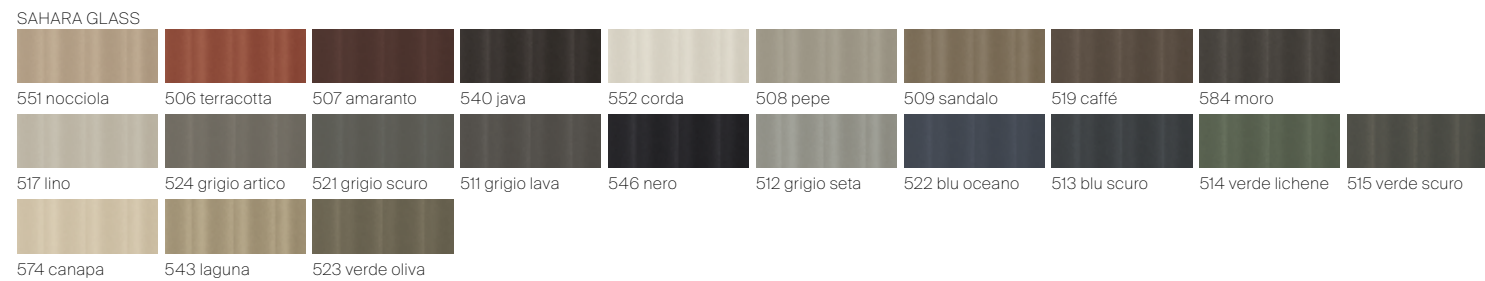
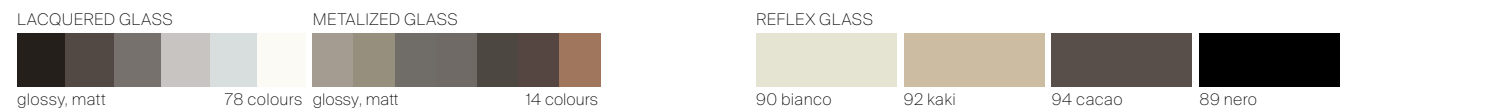

Panels cladding

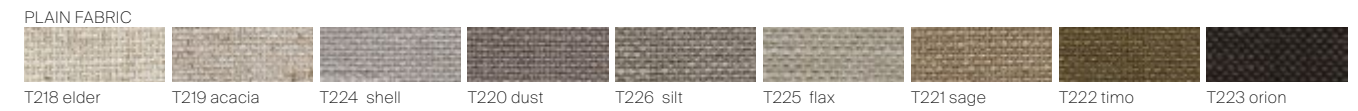
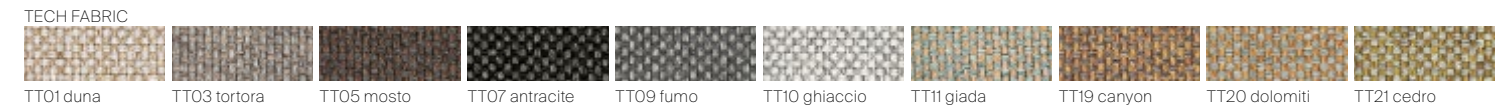
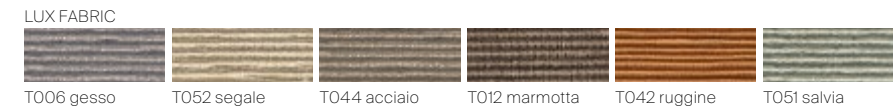

* finishing available also for adjustable lateral filler

Pullover holder

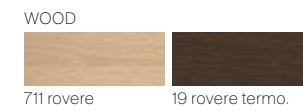

Clothes hanger, inclined shoe shelf, pull out accessories internal cladding, mat for internal lining



FINISHINGS

Shelves

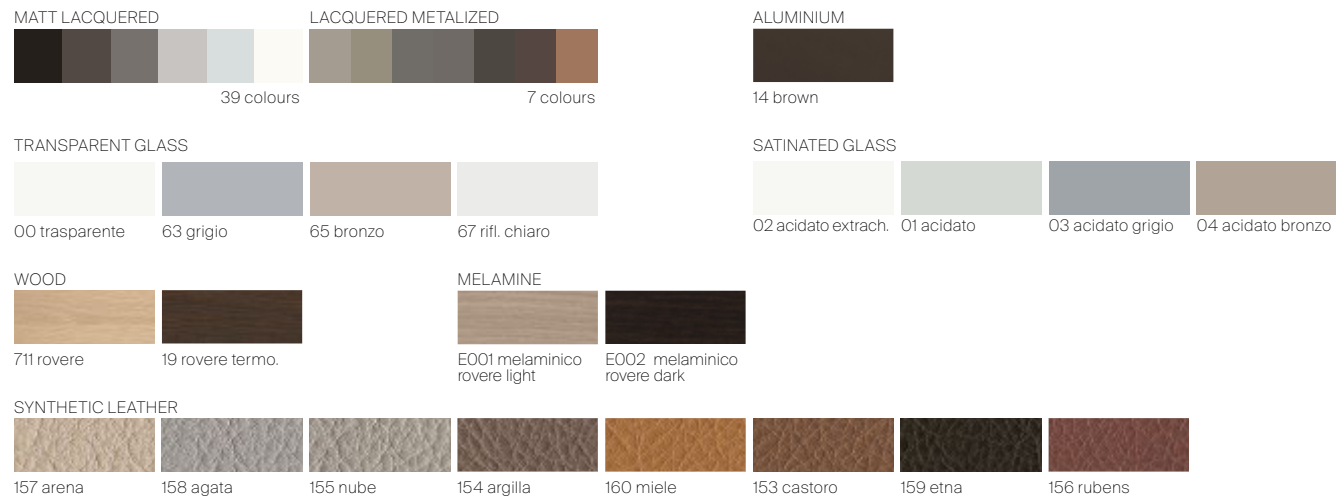

Front for drawers H 128/160/320 with melamine interior

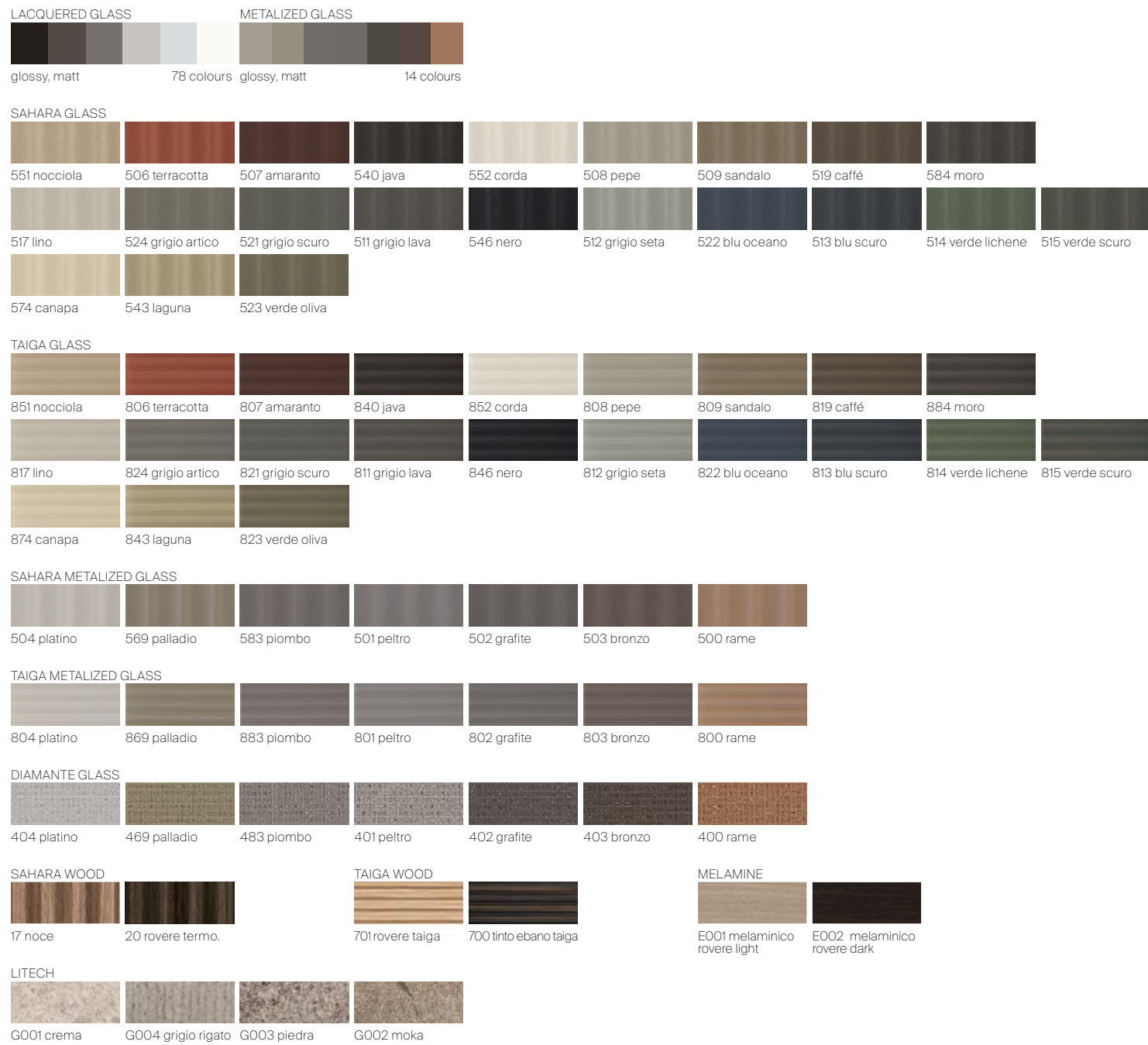

Suspended units top and drawer units top

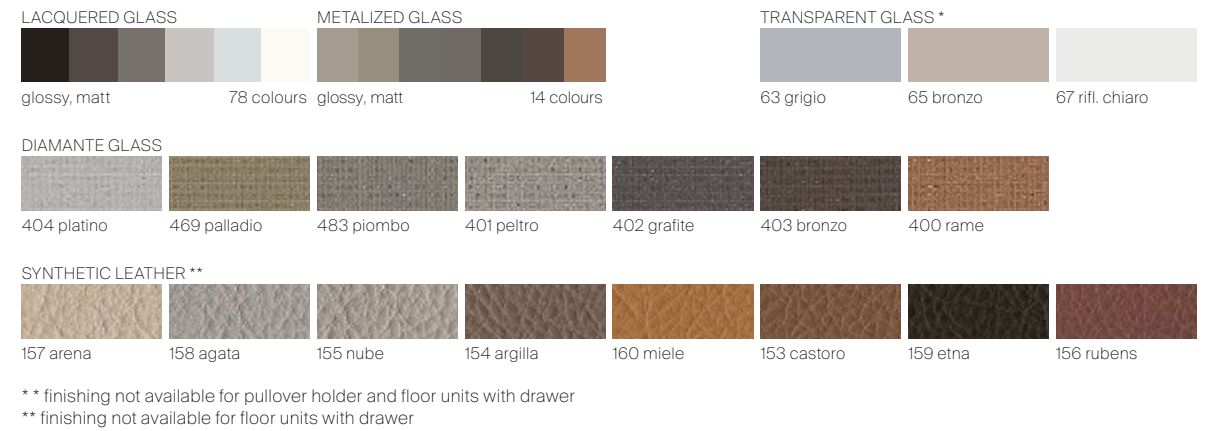

H 128 drawer fronts with internal lining

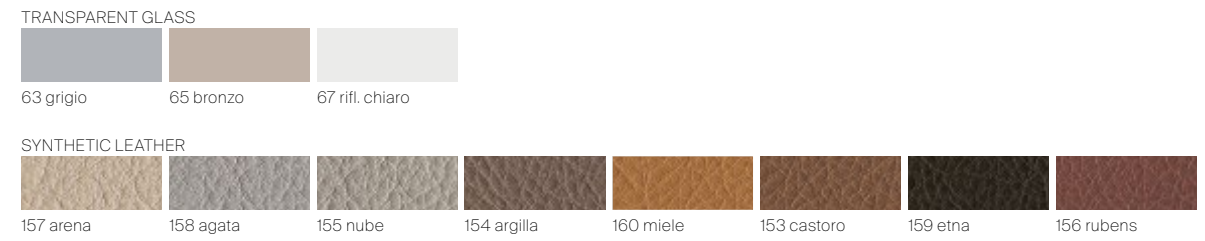

Internal lining for H 128 drawers

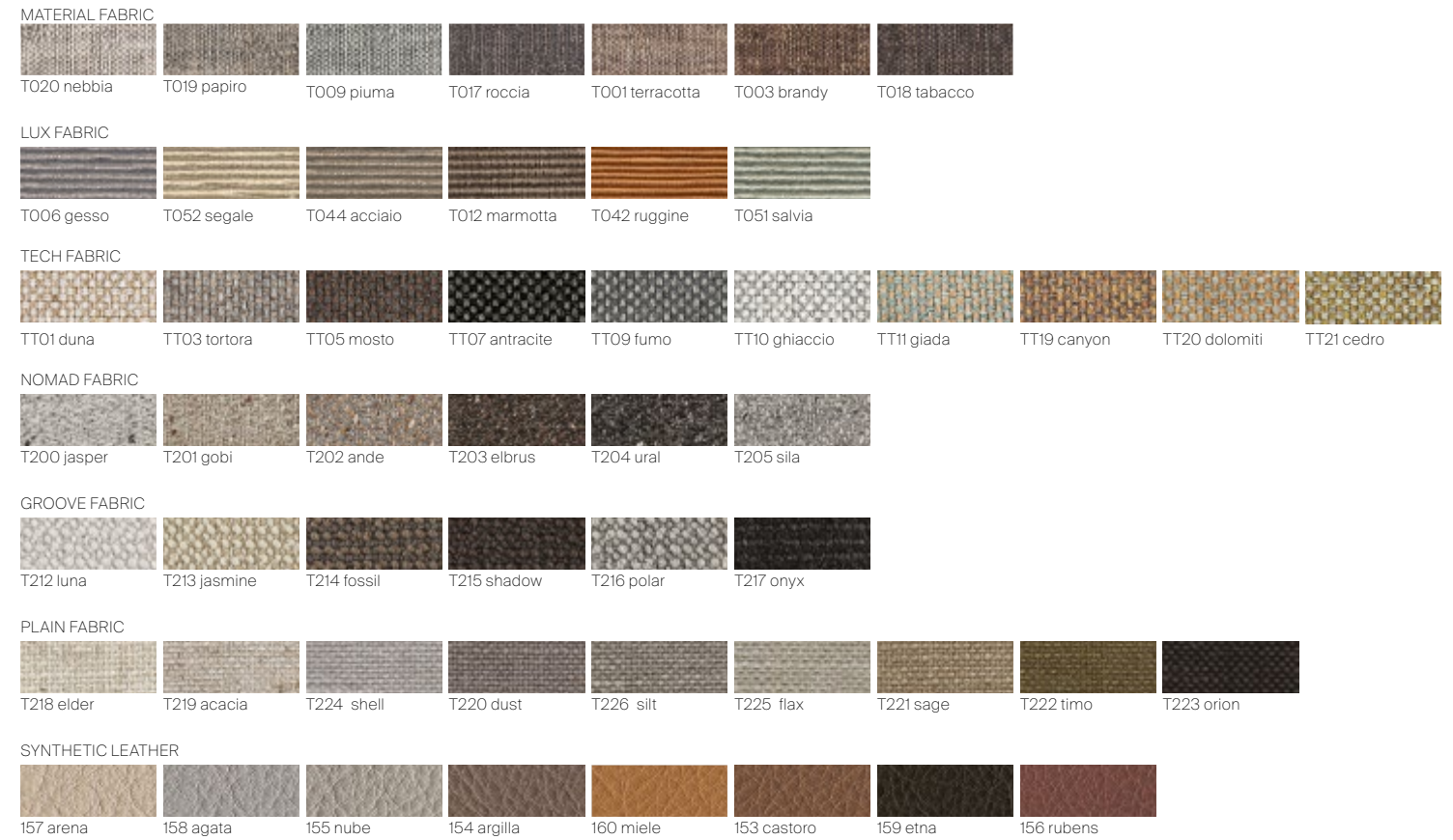

Internal structure for drawer units and floor units with drawer



QUALITY AS THE MAIN PURPOSE, ALWAYS AND IN EVERY ASPECT, WITH THIS MISSION RIMADESIO IS CONSTANTLY SEARCHING FOR SOLUTIONS TO IMPROVE ITS OWN ECOLOGICAL STANDARDS.

OBJECTIVE OBTAINED THANKS TO THE USE OF PRECIOUS AND RECYCLABLE MATERIALS, TO THE ABSENCE OF SUBSTANCES THAT CAN BE TOXIC TO HUMANS OR HARMFUL TO THE ENVIRONMENT IN EVERY PHASE OF THE PRODUCTIVE PROCESS, TO THE USE OF TECHNOLOGY AND EVOLVED MACHINERY, POWERED BY CLEAN ENERGY DERIVED FROM PHOTOVOLTAIC SYSTEMS, INSTALLED ON THE GIUSSANO HEADQUARTERS ROOF.

ALUMINIUM, GLASS, WOOD: FULLY RECYCLABLE AND PARTLY ALREADY RECYCLED MATERIALS.

PROOFS OF A REINFORCED GREEN DNA AND WIDE COHERENCE, SIGNALS OF A CONTINUOUS RESEARCH AND A GLANCE TOWARDS THE FUTURE, THAT TAKES SHAPE IN THE TECHNOLOGICAL INNOVATION OF SYSTEMS, DOORS AND FURNITURE, MADE WITH THE AWARENESS OF WANTING TO ENTRUST HUMANS ONLY WITH HIGH VALUE-ADDED ACTIVITIES.

EXCELLENCE SUSTAINABILITY PROJECT

IT Perseguire la qualità, sempre, sotto tutti gli aspetti. Con questa mission Rimadesio ricerca costantemente soluzioni volte a migliorare i propri standard qualitativi ecologici. Obiettivo ottenuto sinergicamente, grazie all'utilizzo di materiali preziosi e riciclabili, all'assenza di sostanze tossiche per l'uomo e nocive per l'ambiente in ogni fase del processo produttivo, all'impiego di tecnologie e macchinari evoluti alimentati con energia pulita proveniente da impianti fotovoltaici, installati sulla copertura dell'headquarter di Giussano. Alluminio, vetro, legno, materiali totalmente riciclabili e in parte già riciclati, ma anche le vernici prive di solventi di Ecoloursystem e i sistemi di imballaggio ecologici. Testimonianze di un dna green consolidato e di una coerenza trasversale, segnali di una continua attività di ricerca e di uno sguardo sempre proteso al futuro che si declina nell'innovazione tecnologica di sistemi, porte ed arredi, realizzati con la consapevolezza di voler affidare all'uomo solo attività dall'alto valore aggiunto.

DE Stets um Qualität bemüht, und zwar in allen Bereichen. Mit dieser Mission im Blick sucht Rimadesio laufend nach Lösungen, um seine ökologischen Qualitätsstandards zu verbessern. Dieses Ziel wurde dank der Verwendung wertvoller und wiederverwertbarer Materialien, dem Verzicht auf für den Menschen giftige und umweltschädliche Stoffe in jeder Phase des Produktionsprozesses und dem Einsatz fortschrittlicher Technologien und Maschinen, die mit sauberer Energie aus den auf dem Dach des Giussano-Hauptsitzes installierten Photovoltaikanlagen betrieben werden, synergetisch erreicht. Aluminium, Glas, Holz, vollständig recycelbare und teilweise bereits recycelte Materialien, aber auch die lösungsmittelfreien Farben von Ecoloursystem und umweltfreundliche Verpackungssysteme. Ein Zeugnis einer fundierten grünen DNA und einer transversalen Kohärenz, Zeichen einer kontinuierlichen Forschungstätigkeit und eines stets in die Zukunft gerichteten Blicks, der sich in der technologischen Innovation von Systemen, Türen und Einrichtungsgegenständen ausdrückt, die in dem Bewusstsein realisiert werden, den Menschen nur Tätigkeiten mit hohem Mehrwert anzuvertrauen.

FR Poursuivre la qualité, toujours, et à tous les égards. Avec cette mission Rimadesio recherche constamment de solutions au fin d'améliorer ses normes de qualité écologique. Objectif atteint, grâce à l'utilisation de matériaux précieux et recyclables, l'absence à chaque étape de la production de substances toxiques nocives pour l'homme et l'environnement, l'utilisation de technologies et des machines avancées alimentées par l'énergie solaire après l'installation sur le toit de l'usine à Giussano de systèmes photovoltaïques. Aluminium, verre, bois, des matériaux entièrement recyclables et déjà en partie recyclés, mais aussi peinture Ecoloursystem sans solvants et systèmes d'emballage respectueux de l'environnement. Témoignages d'un adn "vert" consolidé et d'une cohérence transversale, signes de recherche continue et d'une tendance à regarder en avant, qui correspond bien à l'innovation technologique des systèmes, des portes et des meubles, réalisés avec la conscience que l'apport de l'homme dans la production ne peut qu'avoir un valeur ajoutée.

ES Perseguir la calidad, siempre, en todos los aspectos. Con esta misión Rimadesio busca constantemente soluciones destinadas a mejorar sus estándares de calidad ecológica. Objetivo conseguido sinérgicamente, gracias al uso de materiales preciosos y reciclables, a la ausencia de sustancias tóxicas para los seres humanos y nocivas para el medio ambiente en cada etapa del proceso de producción, al uso de tecnologías y máquinas avanzadas alimentadas por energía limpia a partir de sistemas fotovoltaicos, instalados en la cobertura del headquarter de Giussano. Aluminio, cristal, madera, materiales completamente reciclables y, en parte, ya reciclados, sino también las pinturas Ecoloursystem libres de disolventes y los sistemas de embalaje ecológicos. Testimonios de un adn green consolidado y una coherencia transversal, señales de una continua investigación y de una vista siempre tendida al futuro que se declina en la innovación tecnológica de sistemas, puertas y muebles, realizados con el conocimiento que desea confiar al hombre sólo actividades de alto valor añadido.

RU Обеспечение качества всегда и во всем. И, в том числе, для достижения этой цели Компания Rimadesio находится в постоянном поиске решений, направленных на улучшение экологических стандартов качества. Эта цель была достигнута благодаря использованию на каждом этапе производственного процесса ценных материалов, пригодных для вторичной переработки, отсутствию токсичных для человека и вредных для окружающей среды веществ, а также благодаря внедрению передовых технологий и оборудования, работающего на чистой энергии от фотоэлектрических систем, установленных на крыше штаб-квартиры компании в г. Джуссано. Компания использует такие материалы, как алюминий, стекло, дерево – полностью перерабатываемые и уже частично переработанные материалы, краски Ecoloursystem, не содержащие растворителей, а также экологически упаковку. Свидетельство консолидированной экологичности и непрерывной последовательности, исследовательской деятельности и взгляда, всегда устремленного в будущее, что выражается в технологических инновациях систем, дверей и мебели, произведенных с осознанием того, что человеку стоит поручать только деятельность с высокой добавленной стоимостью.

汉语 至始至终追求全方位的卓越品质。Rimadesio 肩负使命，不断探索精进生态质量标准的解决方案。品牌目标之达成有赖于珍贵的可回收材料，该材料在所有制造阶段皆不会产生危害人体和环境之有毒物质，同时结合业界前沿的技术以及先进机械装置；而位于朱塞诺 (Giussano) 品牌总部建筑屋顶上的光伏发电设备为上述之机械装置供给干净的能源。除了可完全回收和已部分回收的铝材、玻璃、木材等材料之外，还有环保色彩系统 (Ecoloursystem) 的无溶剂涂料和生态环保型包装。深植的绿色 DNA、跨领域的协同性、持续的研究工作以及具前瞻性的未来展望皆体现在家具系统、各式门类 and 家具配件的技术创新上，其本着信赖人类才能胜任高附加价值活动的意念研发而成。

GUIDE TO RIMADESIO QUALITY

TEMPERED GLASSES

Single tempered glasses cooked at a temperature of 650 °C. Mechanical resistance 5 times superior in comparison to a normal glass. In case of breaking it crumbles in harmless tiny fragments. In accordance with the UNI EN 12150, UNI 7697 and UNI EN 12600 rules with reference to the security of glasses for decoration purposes.

LAMINATED GLASSES

Double glasses. Between the two glasses a thin plastic film is inserted. Transparent and invisible, it perfectly sticks to both surfaces. Both surfaces are perfectly smooth.Resistance to breaking in accordance with the UNI EN ISO 12543, UNI 7697 and UNI EN 12600 rules. The plastic film witholds the fragments in case of breaking.

GLASS WITH METAL NET AND MESH

Double laminated glasses. Between the two extra-clear glasses and two thin plastic films a micronet fabric is inserted. Through a sophisticated process a metal layer is applied on the fabric, thus creating a characteristic effect of semi transparency. The reflections of the light on the surface of the metallic net are provided by using an extra-clear float glass, which allows maximum transparency and high light transmissions, thanks to the low content of iron oxides. Following the process of hot stratification, the fabric might show minor wave effect, which give the material its characteristic materic and natural look.

ECOLORSYSTEM LACQUERED GLASSES

Ecolorsystem is the name that distinguishes the exclusive Rimadesio lacquered glass collection in glossy and matt finishing. Ecological colours produced using exclusively water paints of latest generation, cooked at 110° C. A production technology in the area of glass, with a fully robotised in-house plant that ensures very high quality results and a low environmental impact work cycle. Corrosion resistance conforms to the UNI EN ISO 9227 standard. Temperature fluctuation resistance conforms to the UNI 9429 standard. The colour is inside the double glass, safe from stains, dust and humidity. The thickness of the glass creates an exclusive "depth" effect.

VETRI TEMPERATI

Vetri singoli, sottoposti al trattamento della tempra ovvero ad una cottura alla temperatura di 650 °C. Resistenza meccanica di 5 volte superiore rispetto ad un vetro normale. In caso di rottura si sbriciola in minuti frammenti inoffensivi. Conforma alle norme UNI EN 12150, UNI 7697 e UNI EN 12600 in materia di sicurezza per i vetri d'arredamento.

VETRI STRATIFICATI

Vetri doppi. Fra i due vetri è inserita una sottile pellicola di materiale plastico, trasparente ed invisibile, che aderisce completamente alle due superfici. Entrambe le superfici sono perfettamente lisce. Resistenza alla rottura conforme alle norme UNI EN ISO 12543, UNI 7697 e UNI EN 12600. La pellicola di materiale plastico in caso di rottura trattiene i frammenti.

VETRI STRATIFICATI RETE,

MAGLIA E FIBRA

Vetri doppi stratificati. Tra i due vetri extrachiari e le due sottili pellicole in materiale plastico, è inserito un tessuto in microrete sul quale, tramite un sofisticato processo di materizzazione, viene depositato uno strato metallico che crea un caratteristico effetto di semitrasparenza. Le riflessioni della luce sulla superficie della rete metallizzata sono ottenute con l'utilizzo del vetro float extrachiaro che, grazie al basso contenuto di ossidi di ferro, garantisce la massima trasparenza e un'elevata trasmissione luminosa. Il tessuto, a seguito del processo di stratifica a caldo, può presentare delle leggere ondulazioni che conferiscono al materiale il suo caratteristico aspetto materico e naturale.

VETRI LACCATI ECOLORSYSTEM

Ecolorsystem è la denominazione che contraddistingue l'esclusiva collezione di vetri laccati Rimadesio, disponibili in finitura lucida e opaca. Colori ecologici perchè prodotti utilizzando esclusivamente vernici all'acqua di ultima generazione, con cottura a 110°C. Una tecnologia produttiva all'avanguardia nell'ambito del vetro, con impianti interni totalmente robotizzati che assicurano risultati di altissima qualità e un ciclo di lavorazione a basso impatto ambientale. Resistenza alla corrosione conforme alla norma UNI EN ISO 9227. Resistenza agli sbalzi di temperatura conforme alla norma UNI 9429. Colori inalterabili nel tempo perchè applicati sulla superficie interna del vetro, al sicuro da macchie, polvere e umidità. Lo spessore del vetro crea un esclusivo effetto di "profondità".

TEMPERIERTES GLAS

Einzelgläser, die einer Härtingsbehandlung oder einer Kochtemperatur von 650 °C unterzogen wurden. Mechanische Beständigkeit 5 mal höher als bei normalem Glas. Im Bruchfall zerbröckeln harmlose Bruchstücke in Minuten. Entspricht den Normen UNI EN 12150, UNI 7697 und UNI EN 12600 für die Sicherheit von Möbelgläser.

SCHICHTGLAS

Doppelgläser. Zwischen den beiden Gläsern befindet sich ein dünner Film aus transparentem und unsichtbarem Kunststoff, der vollständig an den beiden Oberflächen haftet. Beide Oberflächen sind komplett glatt. Die Bruchfestigkeit entspricht den Normen UNI EN ISO 12543, UNI 7697 und UNI EN 12600. Die Kunststoffolie bewahrt im Bruchfall die Bruchstücke.

SCHICHTGLAS MIT METALLNETZ,

GLASGITTER UND FASER

Hierbei handelt es sich um Doppelschichtgläser. Zwischen den zwei Extralight-Glasscheiben und den beiden unsichtbaren Plastikfolien wird ein Metallnetz eingesetzt. Das kriert einen besonderen halbtransparenten Effekt. Der Widerschein des Lichtes auf der Oberfläche des Metallnetzes wird durch die Verwendung von Extralight Float Glas erzielt. Dank eines kleinen Anteils von Eisenoxid haben wir die maximale Lichtdurchlässigkeit und eine sehr hohe Lichtübertragung erzielen können. Das Netz kann nach dem unter Hitze durchgeführten Schichtungsverfahren leichte Welle aufweisen, was dem Material ein natürliches Aussehen verleiht.

LACKIERTE GLÄSER ECOLORSYSTEM

Ecolosystem ist der Name der lackierten Glas-Kollektion von Rimadesio in der glänzend und matte Ausführung verfügbar. Absolut oekologische Farben, da die modernsten Lackierungen, auf Wasser-Basis, an einer Temperatur von 110° gekocht werden. Eine fortschrittliche Produktionstechnik in der Glasverarbeitung auf einer vollautomatisierten Anlage, die Ergebnisse höchster Qualität und gleichzeitig umweltfreundliche Verarbeitungsverfahren gewährleistet. Korrosionsprüfung gemäß Bestimmung UNI EN ISO 9227. Temperaturwechselprüfung gemäß Bestimmung UNI 9429. Unverändliche Farben da die Farbung sich im Innen des Doppelglases, geschützt vor Staub, Kratzen und Feuchtigkeit, findet. Die Dicke des Glases erzeugt eine einzigartige Tiefwirkung.

VERRES TREMPÉS

Verres simples, soumis au traitement de trempe et donc à une température de cuisson de 650 °C. Résistance mécanique 5 fois supérieure à celle du verre normal. En cas de rupture, des fragments inoffensifs s'effritent en quelques minutes. Conforme aux normes UNI EN 12150, UNI 7697 et UNI EN 12600 pour la sécurité des verres pour les meubles.

VERRES STRATIFIÉS

Doublе verres. Entre les deux verres se trouve une fine pellicule de matière plastique, transparente et invisible, qui adhère complètement aux deux surfaces. Les deux surfaces sont parfaitement lisses. La résistance aux ruptures est conforme aux normes UNI EN ISO 12543, UNI 7697 et UNI EN 12600. La pellicule retient les fragments en cas de rupture.

VERRE FEUILLETÉ AVEC NET,

MAILLE ET FIBRA

Double verre stratifié. Entre les deux verres extra clair et les deux films fins de matière plastique un tissu en micro maille est ajouté. A travers un procédé avancé de materisation un couche métallique est déposé sur ce tissu, créant un effet caractéristique translucide. Les reflets de la lumière sur la surface de la maille métallique sont obtenus avec l'utilisation du verre float extra clair, qui, grâce à un faible teneur de oxydes de fer, permet un maximum de transparence et de transmission de la lumière. Suite au procédé de stratification à chaud, le tissu peut présenter de petites ondulations, qui apportent au matériau son aspect caractéristique et naturel.

VERRES LAQUÉS ECOLORSYSTEM

Ecolorsystem est le nom qui caractérise la collection exclusive de verres laqués de Rimadesio disponibles en finition brillante et mate. Couleurs écologiques, parce que produites en utilisant exclusivement vernis à l'eau de dernière génération, cuites à 110°. Une technologie de production avant-gardiste dans le domaine du verre, avec des équipements internes entièrement robotisés qui assurent des résultats de grande qualité et un cycle de production ayant un impact très faible sur l'environnement. Résistance à la corrosion conformément à la norme UNI EN ISO 9227. Résistance aux écarts de température conformément à la norme UNI 9429. Couleurs inaltérables parce qu'ils sont appliqués dans la surface interne du verre, pour protéger de la poussière humidité et taches. L'épaisseur du verre crée un exclusif effet profondeur.

CRISTALES TEMPLADOS

Vidrios simples, sometidos al tratamiento de templado a una temperatura de cocción de 650 °C. Resistencia mecánica de 5 veces mayor que el vidrio normal. En caso de rotura, se desmoronan fragmentos inofensivos. Conforme a las normas UNI EN 12150, UNI 7697 y UNI EN 12600 en materia de seguridad para los cristales en el amueblamiento.

CRISTALES ESTRATIFICADO

Vidrios dobles. Entre los dos vidrios hay una película fina de material plástico, transparente e invisible, que se adhiere completamente a las dos superficies. Ambas superficies son perfectamente lisas. La resistencia a la rotura cumple con las normas UNI EN ISO 12543, UNI 7697 y UNI EN 12600. La película de plástico en caso de rotura retiene los fragmentos.

CRISTALES ESTRATIFICADOS RED

MÉTALICA, MAILLA Y FIBRA

Cristales dobles estratificados. Entre los dos cristales extraclaros y las dos capas sintéticas, está inserido en un tejido de microred en el que, a través de un sofisticado proceso se deposita una característica de efecto semitransparente. Los reflejos de la luz sobre la superficie de la red metálica se proporcionan con el uso del vidrio float extraclaro que, gracias a su bajo contenido en óxidos de hierro, asegura la máxima transparencia y una alta transmisión de luz. El tejido, siguiendo el proceso de estratificación en caliente, puede presentar ligeras ondulaciones que dan al material su aspecto característico natural.

CRISTALES LACADOS ECOLORSYSTEM

Ecolorsystem es la denominación que marca la exclusiva colección de los cristales lacados Rimadesio, disponibles en acabado brillante y mate. Colores ecológicos porque productos utilizando exclusivamente pinturas al agua de última generación, con cocción a 110°. Una tecnología productiva a la vanguardia en el ámbito del cristal, con unas instalaciones internas totalmente robotizadas que aseguran resultados de altísima calidad y un ciclo de tratamiento respetuoso del medio ambiente. Resistencia a la corrosión conforme a la norma UNI EN ISO 9227. Resistencia a las variaciones de temperatura conforme a la norma UNI 9429. Colores inalterables en el tiempo porque aplicados en la superficie interior del cristal, al resguardo de manchas, polvo y humedad. El grosor del cristal crea un exclusivo efecto de "profundidad".

ЗАКАЛЕННОЕ СТЕКЛО

Механическая прочность одинарных стекол, подвергнутых закалке, т.е. обжигу при температуре 650°С, в 5 раз выше, чем у обычного стекла. Если такое стекло разбить, оно рассыпется на мелкие неопасные осколки. Соответствует стандартам безопасности UNI EN 12150, UNI 7697 и UNI EN 12600 для мебельного стекла.

МНОГОСЛОЙНОЕ СТЕКЛО

Двойные стекла. Тонкая, прозрачная и невидимая пластиковая пленка прокладывается между двумя стеклами и полностью приклеивается к обеим поверхностям. Обе поверхности идеально гладкие. Проверка прочности на разрыв была выполнена в соответствии со стандартами UNI EN ISO 12543, UNI 7697 и UNI EN 12600. Эта пленка способна удерживать осколки разбившегося стекла.

МНОГОСЛОЙНОЕ СТЕКЛО, СТЕКЛО С СЕТКОЙ

Многослойное двойное стекло. Между двумя сверхпрозрачными стеклами и двумя тонкими пластиковыми пленками вставляется микросетчатое полотно, на которое в ходе сложного производственного процесса наносится металлический слой, благодаря чему и формируется характерный полупрозрачный эффект. Отражение света на поверхности металлизированной сетки достигается за счет использования сверхчистого флот-стекла, которое из-за низкого содержания оксида железа гарантирует максимальную прозрачность и высокую светопропускную способность. В результате процесса наслаивания в горячем виде полотно приобретает небольшие волнистости, которые придают материалу характерную текстуру и натуральный вид.

ЛАКИРОВАННОЕ СТЕКЛО ECOLORSYSTEM

Ecolorsystem — это название эксклюзивной коллекции лакированного стекла Rimadesio, доступной в глянцевой и матовой отделке. Коллекция характеризуется мягкими спокойными цветами, поскольку при их производстве используются только краски последнего поколения на водной основе, запекаемые при температуре 110°С. В стекольной промышленности в настоящее время внедряются современные производственные технологии, полностью роботизированные заводы, обеспечивающие высокое качество и незначительное воздействие на окружающую среду. Коррозионная стойкость соответствует требованиям положений стандарта EN ISO 9227. Устойчивость к изменениям температуры соответствует требованиям стандарта UNI 9429. Цвет характеризуется исключительной долговечностью, поскольку краски наносятся на внутреннюю поверхность стекла, защищенную от пятен, пыли и влаги. Толщина стекла создает уникальный эффект «глубины».

钢化玻璃

单片玻璃通过淬火工艺,即经 650 °C 高温烧制而成,其机械阻力相较于普通玻璃高出 5 倍。钢化玻璃破裂时会碎成不易伤人的细小碎片。符合家具玻璃安全材质 UNI EN 12150、UNI 7697 以及 UNI EN 12600 的标准。

夹层玻璃

双层玻璃。在两片玻璃之间夹有一层纤薄、透明、无形的塑料薄膜,其完全贴合两片玻璃的表面。两片玻璃的表面皆光滑无比。其抗裂性能符合 UNI EN ISO 12543、UNI 7697 以及 UNI EN 12600 的标准。玻璃破裂时,其碎片会粘在塑料薄膜上,裂而不散。

网夹层玻璃、网格夹层玻璃和纤维夹层玻璃
双层夹层玻璃。在两片超清玻璃和两层纤薄的塑料薄膜之间夹入一层微型网状织物,一道细腻的材质加工工艺,会在织物上覆盖一层金属并创造出半透明的特殊效果。使用超清浮法玻璃产出金属网表面的光线反射,因玻璃的氧化铁含量低,可确保最大透明度和高透光率。通过热分层加工工艺,夹入的织物会有不平整的现象,从而呈现出具有特色的材质纹理和自然感的外观。

环保色彩系统 (Ecolorsystem) 的烤漆玻璃
Ecolorsystem 为 Rimadesio 烤漆玻璃独家系列的名称,有亮面和哑光两种表面处理可供选择。由于仅使用最新一代的水性涂料搭配 110°C 烘烤工序完成而被称为生态环保性色彩;其为超前玻璃业界的生产技术,而全机器人化的内部设备确保极高的产品质量和低环境冲击的加工循环。其抗腐蚀程度符合 UNI EN ISO 9227 的标准。其抗温度急变性符合 UNI 9429 的标准。因色彩涂层夹于玻璃内层,因此不会褪色且不受脏污、灰尘和湿气的影响。玻璃的厚度创造出一种独特的“深度”效果。

ECOLORSYSTEM LACQUERED GLASS

GLOSSY MATT		GLOSSY MATT		GLOSSY MATT		GLOSSY MATT		GLOSSY MATT		GLOSSY MATT			
305	138 cipria	45	97 avorio	59	105 grigio chiaro	40	115 grigio cenere	53	95 bianco neve	50	108 bianco latte		
51	113 nocciola	52	107 corda	56	98 lino	312	145 grigio seta	47	96 grigio perla	78	114 sabbia		
306	139 terracotta	85	130 tufo	310	143 creta	38	121 azzurro cera	36	117 blu Londra	74	110 canapa		
76	116 rosso india	308	141 pepe	317	600 grigio artico	35	100 blu notte	39	122 verde inglese	73	109 giallo kashmir		
75	129 amaranto	309	142 sandalo	88	132 grigio scuro	86	131 blu oceano	314	147 verde lichene	43	119 laguna		
307	140 java	58	99 caffè	311	144 grigio lava	313	146 blu scuro	315	148 verde scuro	33	111 verde oliva		
		84	128 moro	46	102 nero					316	149 verde terra		

ECOLORSYSTEM METALIZED GLASS

GLOSSY MATT		SAHARA		TAIGA		DIAMANTE	
304	137 platino	504	platino sahara	804	platino taiga	404	platino diamante
69	126 palladio	569	palladio sahara	869	palladio taiga	469	palladio diamante
83	127 piombo	583	piombo sahara	883	piombo taiga	483	piombo diamante
301	134 peltro	501	peltro sahara	801	peltro taiga	401	peltro diamante
302	135 grafite	502	grafite sahara	802	grafite taiga	402	grafite diamante
303	136 bronzo	503	bronzo sahara	803	bronzo taiga	403	bronzo diamante
300	133 rame	500	rame sahara	800	rame taiga	400	rame diamante

ECOLORSYSTEM SAHARA GLASS

551	nocciola sahara	552	corda sahara	517	lino sahara	512	grigio seta sahara	514	verde lichene sahara	574	canapa sahara
506	terracotta sahara	508	pepe sahara	524	grigio artico sahara	522	blu oceano sahara	515	verde scuro sahara	543	laguna sahara
507	amaranto sahara	509	sandalo sahara	521	grigio scuro sahara	513	blu scuro sahara			523	verde oliva sahara
540	java sahara	519	caffè sahara	511	grigio lava sahara						
		584	moro sahara	546	nero sahara						

NEUTRAL GLASS

55	specchio
68	specchio grigio

TRANSPARENT GLASS

890	trasparente taiga
590	trasparente sahara
490	trasparente diamante
05	trasparente extrachiaro
00	trasparente
63	grigio trasparente
65	bronzo trasparente
390	verde trasparente
391	blu trasparente

SATINATED GLASS

67	riflettente chiaro
64	riflettente grigio
81	riflettente bronzo
891	acidato taiga
591	acidato sahara
02	acidato extrachiaro
01	acidato
03	acidato grigio
04	acidato bronzo
82	nuvola extrachiaro
80	nuvola

MESH GLASS

60	rete alluminio
61	rete inox
62	rete bronzo
66	maglia gold
87	maglia rame
06	fibra argento
08	fibra bronzo

REFLEX GLASS

90	bianco reflex
92	kaki reflex
94	cacao reflex
89	nero reflex

ECOLORSYSTEM TAIGA GLASS





851	nocciola taiga	852	corda taiga	817	lino taiga	812	grigio seta taiga	814	verde lichene taiga	874	canapa taiga
806	terracotta taiga	808	pepe taiga	824	grigio artico taiga	822	blu oceano taiga	815	verde scuro taiga	843	laguna taiga
807	amaranto taiga	809	sandalo taiga	821	grigio scuro taiga	813	blu scuro taiga			823	verde oliva taiga
840	java taiga	819	caffè taiga	811	grigio lava taiga						
		884	moro taiga	846	nero taiga						

GUIDE TO RIMADESIO QUALITY					
ALUMINIUM	ALLUMINIO	ALUMINIUM	ALUMINIUM	ALUMINIO	АЛЮМИНИЙ
POWDER LACQUERED FINISHING <p>Detachment resistance of the layer of powder paint conforms to the norm. Corrosion resistance of the powder paint conforms to Machu test results and to the norm. Fingerprint resistance of the powder paint conforms to the norm.</p>	FINITURA ANODIZZATA <p>Resistenza all'abrasione della finitura anodizzata conforme alla norma. Resistenza alla corrosione della finitura anodizzata conforme alla norma.</p>	ELOXIERTES FINISH <p>Die Abriebfestigkeit der anodisierten Oberfläche entspricht der Norm. Korrosionsbeständigkeit der Standard-Eloxal-Oberfläche.</p>	FINITION ANODISÉE <p>Résistance à l'abrasion de la finition anodisée est conforme à la norme. Résistance à la corrosion de la finition anodisée est conforme à la norme.</p>	ACABADO ANODIZADO <p>Resistencia a la abrasión del acabado anodizado cumple con la norma. Resistencia a la corrosión del acabado anodizado cumple con la norma.</p>	АНОДИРОВАННОЕ ПОКРЫТИЕ <p>Стойкость анодированного покрытия к истиранию соответствует требованиям стандарта. Коррозионная стойкость анодированного покрытия соответствует требованиям стандарта.</p>
GLOSSY ALUMINIUM FINISHING <p>The glossy aluminium is realized through the procedure of scraping and polishing of the aluminium, both artisanal processes carried out through last generation plants.</p>	FINITURA LACCATA A POLVERE <p>Resistenza al distacco dello strato di vernice a polvere conforme alla norma. Resistenza alla corrosione della vernice a polvere conforme ai risultati del Machu Test e alla norma. Resistenza all'impronta della vernice a polvere conforme alla norma.</p>	PULVERLACKIERUNG <p>StandardgemäÙe Beständigkeit gegen das Ablösen der Pulverbeschichtungs-schicht. Korrosionsbeständigkeit der Pulverbeschichtung gemäß den Ergebnissen des Machu-Tests und des Standards. Die Beständigkeit gegenüber dem Abdruck der Pulverbeschichtung entspricht dem Standard.</p>	FINITION LAQUÉE À POUVRE <p>Resistencia al desprendimiento de la capa de pintura conforme à la norme. Résistance à la corrosion de la peinture à poudre conforme au Machu test et à la norme. Résistance à l'empreinte de la peinture à poudre conforme à la norme.</p>	ACABADO LACADO EN POLVO <p>Resistencia al desprendimiento de la capa de laca en polvo cumple con la norma. Resistencia a la corrosión de la laca en polvo conforme con los resultados de la prueba del Machu Test y con la norma. Resistencia a la impresión de la laca en polvo cumple con la norma.</p>	ПОРОШКОВОЕ ПОКРЫТИЕ С ЛАКОВЫМ ЭФФЕКТОМ <p>Стойкость порошкового покрытия к отслаиванию соответствует требованиям стандарта. Коррозионная стойкость порошкового покрытия соответствует результатам теста Маху и требованиям стандарта. Определение твердости порошкового покрытия соответствует требованиям стандарта.</p>
NICKEL GRIGIO FINISHING <p>The nickel grigio finishing is obtained through several painting layers with the latest generation of enamels, capable of creating the appearance of the most natural metal oxidations. The special glossy effect is the result of a manual brushing and polishing process carried out on the raw material.</p>	FINITURA ALLUMINIO LUCIDO <p>L'alluminio lucido viene realizzato mediante la spazzolatura e la brillantatura dell'alluminio, entrambi processi artigianali eseguiti tramite impianti di ultima generazione.</p>	GLÄNZENDES ALUMINIUM-FINISH <p>Poliertes Aluminium wird durch Bürsten und Polieren von Aluminium erreicht, wobei beide handwerklichen Verfahren durch die neuesten Energieerzeugungssysteme ausgeführt werden.</p>	FINITION ALUMINIUM POLI <p>L'aluminium poli est réalisé par le rayure et polissage de l'aluminium, deux procédés artisanaux réalisés par des équipements de dernière génération.</p>	ACABADO DE ALUMINIO BRILLANTE <p>El aluminio pulido se produce mediante rayadura y pulido de aluminio, ambos procesos artesanales realizados por medio de sistemas de última generación.</p>	ГЛЯНЦЕВАЯ АЛЮМИНИЕВАЯ ОТДЕЛКА <p>Глянцевый алюминий производится путем браширования и полировки алюминия, причем оба процесса выполняются вручную на самом современном оборудовании.</p>
ANODIZED FINISHING <p>Abrasion resistance of the anodised finish conforms to the norm. Corrosion resistance of the anodised finishing conforms to the norm.</p>	FINITURA NICKEL GRIGIO <p>La finitura nickel grigio viene ottenuta mediante diversi passaggi di verniciatura con smalti di ultima generazione, in grado di conferire l'aspetto delle più naturali ossidazioni metalliche. Lo speciale effetto lucido è il risultato di un processo manuale di spazzolatura e brillantatura effettuato sul materiale grezzo.</p>	NICKEL GRIGIO-FINISH <p>Das Nickel grigio wird durch mehrere aufeinanderfolgende Lackierungsvorgänge geschafft. Dazu werden Lacke der neuesten Generation verwendet, die das Aussehen der natürlichsten Metalloxidation verleihen. Der besondere Glanzeffekt wird durch einen manuellen Vorgang von Bürsten und Schleifen auf dem Rohmaterial erreicht.</p>	FINITION NICKEL GRIGIO <p>La finition en nickel grigio est obtenue grâce à plusieurs passages de peinture réalisés avec les émaux de dernière génération, capables de donner une apparence naturelle des oxydations métalliques. L'effet brillant spécial est le résultat d'un processus de broissage et de polissage manuel effectué sur la matière première.</p>	ACABADO DE NICKEL GRIGIO <p>El acabado nickel grigio se obtiene mediante varios pasos de pintura con esmaltes de última generación, capaces de dar el aspecto de las más naturales oxidaciones de metales. El efecto brillante especial es el resultado de un proceso de cepillado manual y pulido realizado sobre la materia prima.</p>	ГЛЯНЦЕВАЯ АЛЮМИНИЕВАЯ ОТДЕЛКА <p>Глянцевый алюминий производится путем браширования и полировки алюминия, причем оба процесса выполняются вручную на самом современном оборудовании.</p>
WOOD <p>Veneered elements, such as tops, cabinets and shelves, are produced by using materials in compliance with current regulations concerning the emissions of formaldehyde. Open pore painting with primer and non-toxic matt transparent acrylic finishing.</p>	ESSENZE <p>Gli elementi impiallacciati, come piani, contenitori e ripiani, sono realizzati utilizzando tranciato conforme alle normative riguardanti le emissioni di formaldeide. Verniciatura a poro aperto con fondo e finitura acrilica atossica opaca trasparente.</p>	HOLZ <p>Die furnierten Elemente wie Sockelböden, Korpusse und Fachböden werden mit Furnier hergestellt, welches den Normen zum Formaldehydausstoß entspricht. Offenporige Lackierung auf Wasserbasis und mit ungiftigem, transparenten Acryllack.</p>	BOIS <p>Les éléments de placage, comme les plateaux, les conteneurs et les étagères, sont produits avec un tranchage conforme aux normes concernant les émissions de formaldéhyde. Verni à pores ouverts avec un apprêt à base d'eau non toxique et finition acrylique mate et transparent.</p>	MADERA <p>Los elementos chapados de madera, como encimeras, contenedores y estantes, se realizan utilizando hojas conforme a las normas sobre las emisiones de formaldehído. Pintura de poro abierto con imprimación a base de agua y acabado acrílico mate transparente atóxico.</p>	ШПОН <p>Шпонированные элементы, такие как столешницы, контейнеры и полки, изготавливаются из шпона, соответствующего нормам выделения формальдегида. Окраска осуществляется при открытых порах с использованием нетоксичной прозрачной матовой акриловой грунтовки и финишного покрытия.</p>
LITECH <p>Ceramic coating obtained through pure minerals melted at high temperatures, by using an innovative full digital printing technique with water-based inks and enamels, which are environmentally friendly and sustainable. Material with permanent antibacterial properties thanks to the action of the negative silver ions, integrated before the final firing treatment at 1200°. Breaking strength in compliance with UNI 7697 and UNI EN 12600 standards. High abrasion resistance.</p>	LITECH <p>Rivestimento ceramico prodotto con minerali purissimi fusi ad alta temperatura e realizzati mediante un'innovativa tecnica di stampa full digital a inchiostri e smalti all'acqua, ecologici e sostenibili. Materiale dotato di proprietà antibatteriche permanenti grazie all'azione degli ioni negativi d'argento integrati prima del trattamento di cottura finale a 1200°. Resistenza alla rottura conforme alle norme UNI 7697 e UNI EN 12600. Elevata resistenza all'abrasione.</p>	LITECH <p>Keramikeroberfläche aus reinen Mineralien produziert, welche bei hohen Temperaturen miteinander verschmolzen werden. Danach kommt ein neues, innovatives, voll digitales Druckverfahren zum Einsatz, welches Farben und Emaille auf Wasserbasis aufträgt. Ein sehr ökologisches und nachhaltiges Verfahren. Dieses Material hat, dank der negativ geladenen Ionen des verwendeten Silbers, welches vor dem letzten Brennprozess bei 1200 °C zugefügt wird, ständige antibakterielle Eigenschaften. Bruchfest entsprechend den Normen UNI 7697 und UNI EN 12600. Hohe Abriebfestigkeit.</p>	LITECH <p>Revêtement en céramique produit avec des minéraux purs fondus à haute température et fabriqué en utilisant une technique d'impression entièrement numérique innovant avec des encres et des émaux à base d'eau, qui sont respectueux de l'environnement et durables. Le matériau possède des propriétés antibactériennes permanentes, grâce à l'action des ions argent négatifs intégrés avant le traitement de cuisson finale à 1200 °. Résistance à la rupture conforme aux normes UNI 7697 et UNI EN 12600. Haute résistance à l'abrasion.</p>	LITECH <p>Recubrimiento cerámico producido con minerales muy puros fundidos a alta temperatura e fabricados con una innovadora técnica de impresión totalmente digital con tintas y esmaltes a base de agua, ecológicos y sostenibles. Material con propiedades antibacterianas permanentes gracias a la acción de los iones negativos de plata integrados antes de la cocción final a 1200°. Resistencia a la rotura conforme a las normas UNI 7697 y UNI EN 12600. Gran resistencia a la abrasión.</p>	LITECH <p>Керамическое покрытие, изготовленное из чистейших минералов, расплавленных при высокой температуре, производится с использованием инновационной технологии полностью цифровой печати с применением экологически чистых и устойчивых красок и глазурей на водной основе. Материал характеризуется постоянным антибактериальным эффектом благодаря действию отрицательных ионов серебра, интегрированных перед окончательной обработкой запеканием при температуре 1200°. Предел прочности в соответствии со стандартами UNI 7697 и UNI EN 12600. Повышенная устойчивость к истиранию.</p>
MARBLE <p>Natural marble manufactured using an artisanal method with state-of-the-art equipment and polished with water-cooled abrasive tools that tend to respect the very nature of the material. Visible defects are to all intents and purposes peculiarities of the material itself.</p>	MARMO <p>Marmi naturali lavorati secondo un metodo artigianale con impianti di ultima generazione e levigati con utensili abrasivi raffreddati ad acqua tendenti a rispettare l'essenza stessa del materiale. I difetti visibili sono a tutti gli effetti peculiarità del materiale stesso.</p>	MARMOR <p>Natürliche Marmorsteine, die nach einer handwerklichen Methode mit modernen Anlagen verarbeitet und mit wassergekühlten Schleifwerkzeugen poliert werden, wobei stets auf die natürliche Beschaffenheit des Materials geachtet wird. Sichtbare Mängel sind in diesem Fall keine Defekte, sondern charakteristische Merkmale des Materials.</p>	MARBRE <p>Marbres naturels travaillés selon une méthode artisanale avec des installations de dernière génération et polis avec des outils abrasifs refroidis par eau, visant à respecter l'essence même du matériau. Les défauts visibles sont en fait des particularités du matériau lui-même.</p>	MÁRMOL <p>Mármoles naturales trabajados artesanalmente con sistemas de última generación y pulidos con herramientas abrasivas refrigeradas por agua, respetando la esencia misma del material. Los defectos visibles son, en todos los aspectos, peculiaridades del propio material.</p>	МРАМОР <p>Натуральный мрамор обрабатывается ремесленными методами с применением самого современного оборудования, шлифовка поверхности производится абразивными инструментами с водяным охлаждением для бережного сохранения свойств материала. Видимые дефекты по сути являются характерными особенностями материала.</p>
TERRAE <p>Manually spatulated material finish, composed of several layers of natural recovered materials (marble, cocciopesto and lava stone) finely ground, processed into a sandy mixture and expertly kneaded with high quality and certified acrylic resins. A thin layer of protective transparent is applied as a surface finish. Any surface imperfections and slight shades of color are to be considered intrinsic characteristics of the craftsmanship and testimony of the authenticity of the product highlighting its uniqueness.</p>	TERRAE <p>Finitura materica spatolata manualmente, composta da materiali di recupero (marmo, cocciopesto e pietra lavica) finemente macinati, trasformati in una miscela sabbiosa e sapientemente impastati con resine acriliche di alta qualità. Come rifinitura superciale viene applicato un sottile strato di trasparente protettivo. Eventuali imperfezioni superficiali e leggere sfumature di colore sono da considerarsi caratteristiche intrinseche della lavorazione artigianale e testimonianza dell'autenticità del prodotto, esaltandone l'unicità.</p>	TERRAE <p>Handgespachteltes Strukmaterial aus fein gemahlenen, wiederverwerteten Materialien (Marmor, Steingut und Lavastein), die zu einer sandigen Mischung verarbeitet und mit hochwertigen Acrylharzen gekonnt vermischt wurden. Als oberflächliches Finish wird eine dünne Schicht eines schützenden Klarlacks aufgetragen. Oberflächliche Unvollkommenheiten und leichte Farbnuancen sind als wesentliche Merkmale der Handwerkskunst und als Beweis für die Echtheit des Produkts zu betrachten und unterstreichen seine Einzigartigkeit.</p>	TERRAE <p>Finition texturée spatulée manuellement, composée de matériaux récupérés (marbre, cocciopesto et pierre de lave) finement broyés, transformés en un mélange de sable et pétrissés avec des résines acryliques de haute qualité. Une fine couche de protection transparente est appliquée en surface. Les éventuelles imperfections superficielles et légères nuances de couleur doivent être considérées comme des caractéristiques inhérentes du travail artisanal et un témoignage de l'authenticité du produit, exaltant son caractère unique.</p>	TERRAE <p>Acabado de material espatulado manualmente, compuesto por materiales reciclados finamente molidos (mármol, cocciopesto "antiguo material de construcción romano, un tipo de mortero impermeable hecho con fragmentos de ladrillo o teja triturados mezclados con cal y agua" y piedra volcánica), transformados en una mezcla arenosa y mezclados expertamente con resinas acrílicas de alta calidad. Se aplica una fina capa protectora transparente como acabado superficial. Cualquier imperfección superficial y ligeras tonalidades de color deben considerarse características intrínsecas de la artesanía y prueban la autenticidad del producto, realizando su singularidad.</p>	TERRAE <p>Фактурная штукатурка, наносимая вручную, в состав которой входит мелкий песок из смеси измельченных вторичных материалов (мрамора, фаянса и лавового камня), искусно смешанный с высококачественными акриловыми смолами. На поверхность наносится тонкий слой прозрачного защитного покрытия. Любые видимые неровности и незначительные вариации расцветки являются характерными особенностями ручной работы и являются признаком аутентичности и уникальности изделия.</p>
					铝合金 <p>阳极氧化表面处理 <p>阳极氧化的表面处理符合耐磨性标准。阳极氧化的表面处理符合耐腐蚀性标准。</p> <p>粉末涂层表面处理 <p>粉末涂层的抗剥落性符合标准。粉末涂层的耐腐蚀性符合马丘试验结果和标准。粉末涂层的抗指纹性符合标准。</p> <p>亮面铝合金表面处理 <p>亮面铝合金经拉丝和抛光加工程序实现，这两项工艺均通过业界最新一代设备完成。</p> <p>镀灰镍表面处理 <p>镀灰镍表面处理使用业界最新一代涂料经多道涂刷程序完成，其呈现出最自然的金属氧化效果。手工涂刷和抛光工艺打造出特殊的光泽感。</p> <p>木质 <p>家具面板、储物柜和层架组合等饰面元素的生产制作皆符合甲醛限值的标准。底漆和透明无毒哑光亚克力表面处理工艺皆开孔喷涂。</p> <p>LITECH <p>陶瓷涂层通过创新的全数字油墨印刷技术和生态永续的环保水性涂料，经高温产出最纯净的熔融矿物制成。在最终的 1200°烘烤步骤之前，会通过一道银离子的涂层工序，使该材质具有永久抗菌的特性。其抗裂性能符合 UNI 7697 以及 UNI EN 12600 的标准。耐磨性高。</p> <p>大理石 <p>我们采用最先进的设备，为天然大理石进行手工加工，并配备水冷式磨具进行抛光处理，旨在尊重大理石的纯粹本质。肉眼可见的缺陷皆属于材质本身的特性。</p> <p>TERRAE <p>手工涂抹纹理的饰面采用精细研磨的再生材料，如：大理石、cocciopesto（由石灰、碎陶片或砖粉混合而成的古罗马建筑材料）以及熔岩石制成；接着将优质的丙烯酸树脂加入其中，均匀调合成沙质浆料。Terrae如同一层涂覆在表面上的特殊薄透保护漆。任何表面瑕疵和细微色差皆应视作该加工工艺的本身特性，其除了亦印证了产品的真实性，亦彰显其独特性。</p></p></p></p></p></p></p></p></p>

ECOLORSYSTEM MATT LACQUERED

 305 cipria	 45 avorio	 59 grigio chiaro	 40 grigio cenere	 53 bianco neve	 16 bianco latte
 51 nocciola	 52 corda	 56 lino	 312 grigio seta	 47 grigio perla	 78 sabbia
 306 terracotta	 85 tufo	 310 creta	 38 azzurro cera	 36 blu Londra	 74 canapa
 76 rosso india	 308 pepe	 317 grigio artico	 35 blu notte	 39 verde inglese	 73 giallo kashmir
 75 amaranto	 309 sandalo	 88 grigio scuro	 86 blu oceano	 314 verde lichene	 43 laguna
 307 java	 58 caffè	 311 grigio lava	 313 blu scuro	 315 verde scuro	 33 verde oliva
	 84 moro	 13 nero			 316 verde terra

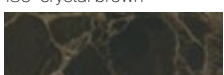
MARBLE

 28 calacatta
 188 sierra beige
 184 crystal grey
 186 crystal brown
 180 emperador
 183 noir saint laurent
 187 verde lepanto
 182 rosso lepanto
 181 nero marquina





MATT MARBLE

 198 calacatta opaco
 194 crystal grey opaco
 191 nero marquina opaco
 185 crystal white opaco







TERRAE

 R006 bone
 R004 sable
 R001 gravel
 R005 river
 R007 saraceno
 R002 vulcano
 R003 navajo





LITECH

 G001 crema
 G002 moka
 G003 piedra
 G004 grigio rigato



ECOLORSYSTEM LACQUERED METALIZED

 304 platino	 302 grafite
 69 palladio	 303 bronzo
 83 piombo	 300 rame
 301 petro	

ALUMINIUM

 31 alluminio lucido
 30 alluminio
 14 brown
 318 nickel grigio
 22 nero lucido

WOOD

 711 rovere
 15 noce
 19 rovere termotrattato
 27 rovere nero
 710 tinto ebano





TAIGA WOOD

 701 rovere taiga
 700 tinto ebano taiga

SAHARA WOOD

 17 noce sahara
 20 rovere termotrattato sahara

MELAMINE

 E001 mel. rovere light
 07 melaminico olmo
 09 melaminico rovere grigio
 25 melaminico larice carbone
 E002 mel. rovere dark

INTERNAL MELAMINE

 UB07 mel. cuoio grigio
 UB09 mel. cuoio brown

GUIDE TO RIMADESIO QUALITY

SYNTHETIC LEATHER

Latest generation material entirely produced in Italy and animal-derived components free, made of: polyester 8%, polyurethane 4%, pcv 88%, textile composition: polyester 100%. It is an exclusive by Rimadesio, resistant and high performing, it is also ortho- phthalates free, in accordance with the European Reach regulation for the protection of human health and the environment from the risks of chemical substances. The production system of Rimadesio synthetic leather complies with current environmental and quality standards.

HIDE LEATHER

Real bovine natural leather, thickness 1,8-2,0 mm, obtained by a process of dyed chromium salt. The surface is pigmented to obtain the different colours of the collection. The surface of the leather may have small imperfections and scars, characteristics that underline the completely natural origin of the leather and, as such, do not diminish its value but enhance its beauty and are not considered defects. Seams made of polyester. Reaction to fire conforms to BS 5852 Cigarette and Match, Cal TB 117 and UNI EN 9175-2010 2.

BLAZE LEATHER

Blaze is a soft hand skin with a smooth surface natural grain, slightly accentuated. The characteristics of resistance to stains and light make this leather an optimal solution for the manufacture of chairs, armchairs and furnishing accessories. Full grain leather, thickness 1,3-1,5 mm, semi aniline, chromium salt tanned. Reaction to fire conforms to BS 5852 Cigarette and Match, CAL TB 117, UNI EN 1021-1, UNI EN1021-2 and NFPA 260/UFAC.

FLARE LEATHER

Full-grain leather characterized by a soft and enveloping hand and a slightly writing effect, capable of creating chiaroscuro effects giving depth to the surfaces it covers. The aniline tincture in cask defines its superior quality, giving softness, elegance and shine. Full grain leather, thickness 1,3-1,5 mm, aniline, chromium salt tanned. Reaction to fire conforms to BS 5852 Cigarette and Match, CAL TB 117, UNI EN 1021-1, UNI EN1021-2 and NFPA 260/UFAC.

RIDGE LEATHER

Ridge is a skin with soft and full hand. The innovative Olivenleder® tanning makes this skin sustainable, chromium- and glutaraldehyde-free by exploiting the natural tanning properties of olives, thanks to the virtuous recovery of the waste generated by the mills during pressing. Pigmented leather, thickness 1,2-1,4 mm, through dyeing aniline, Olivender® tanned. Reaction to fire conforms to BS 5852 Cigarette and Match,CAL TB 117, UNI EN 1021-1, UNI EN 1021-2 e FTP CODE 2010 PART 8.

SIMILPELLE

Materiale di ultima generazione realizzato interamente in Italia e privo di componenti di origine animale, composto da: poliestere 8%, poliuretanica 4%, pvc 88%, composizione tessile: poliestere 100%. Prodotto esclusivo Rimadesio, resistente e altamente performante, privo di orto-ftalati, in linea con il regolamento europeo Reach per la protezione della salute e dell'ambiente dai rischi delle sostanze chimiche. Ogni fase di produzione della similpelle Rimadesio è conforme alle normative vigenti in materia ambientale e di gestione della qualità.

CUOIO

Vero cuoio bovino naturale, spessore di 1,8/2,0 mm, ricavato tramite processo di concia ai sali di cromo. La superficie viene pigmentata per ottenere le varie colorazioni a catalogo. La superficie del cuoio può presentare piccole imperfezioni e cicatrici, caratteristiche che sottolineano l'origine completamente naturale del cuoio e, come tali, non ne sminuiscono il pregio ma ne esaltano la bellezza e non vengono considerati difetti. Cuciture realizzate in poliestere. Reazione al fuoco conforme alle norme BS 5852 Cigarette and Match, Cal TB 117 e UNI EN 9175-2010 2.

PELLE BLAZE

Blaze è una pelle dalla grana naturale e leggermente accentuata. Le caratteristiche di resistenza a macchie e luce rendono questa pelle una soluzione ottimale per la confezione di sedie, poltrone e complementi d'arredo. Pelle pieno fiore dallo spessore 1,3-1,5 mm, semi-anilina, concia ai sali di cromo. Reazione al fuoco conforme alle norme BS 5852 Cigarette and Match, CAL TB 117, UNI EN 1021-1, UNI EN1021-2 e NFPA 260/UFAC.

PELLE FLARE

Pelle caratterizzata da una mano morbida e avvolgente e da un effetto leggermente scrivente, capace di creare effetti di chiaroscuro dando profondità alle superfici che riveste. La tintura all'anilina in botte ne definisce la qualità superiore, conferendo morbidezza, eleganza e lucentezza. Pelle pieno fiore dallo spessore 1,3-1,5 mm, anilina, concia ai sali di cromo. Reazione al fuoco conforme alle norme BS 5852 Cigarette and Match, CAL TB 117, UNI EN 1021-1, UNI EN1021-2 e NFPA 260/UFAC.

PELLE RIDGE

Ridge è una pelle dalla mano morbida e piena. L'innovativa concia Olivenleder® rende questa pelle sostenibile, senza cromo e glutaraldeide sfruttando le proprietà concianti naturali delle olive, grazie al recupero virtuoso dello scarto generato dai frantoi durante la spremitura. Pelle dallo spessore 1,2-1,4 mm, pigmentata all'anilina passante, concia Olivenleder®. Reazione al fuoco conforme alle norme BS 5852 Cigarette and Match, CAL TB 117, UNI EN 1021-1, UNI EN 1021-2 e FTP CODE 2010 PART 8.

KUNSTLEDER

Vollständig in Italien hergestelltes hoch-modernes Material ohne Bestandteile tierischen Ursprungs, bestehend aus: 8% Polyester, 4% Polyurethan, 88% PVC; Textilzusammensetzung: 100% Polyester. Dies ist ein exklusives, widerstandsfähiges und leistungsstarkes Rimadesio Produkt, das gemäß der europäischen Reach- Verordnung keine Ortho-Phthalate enthält. Dies dient zum Schutz der Gesundheit und Umwelt vor den Risiken chemischer Substanzen. Jede Stufe der Kunstlederproduktion von Rimadesio entspricht den geltenden Umwelt- und Qualitätsmanagement Vorschriften.

LEDER

Echtes Rindsleder, mit einer Dicke von 1,8/2,0 mm, gewonnen durch ein Chromsalzgerbverfahren. Die Oberfläche wird pigmentiert, um die verschiedenen Farbtöne zu erzielen. Das Leder kann kleine Unregelmäßigkeiten und Narben aufweisen, die die gänzlich natürliche Herkunft des Leders unterstreichen. Diese Merkmale mindern nicht den Wert, sondern heben vielmehr die Schönheit des Materials hervor und werden nicht als Mängel betrachtet. Die Nähte sind aus Polyester gefertigt.Brandschutz: Entspricht den Normen BS 5852 (Zigarette und Streichholz-Test), Cal TB 117 und UNI EN 9175-2010 2. utsc.

BLAZE LEDER

Blaze ist ein Leder mit natürlicher und leicht betonter Narbung. Die Widerstandsfähigkeit gegenüber Flecken und Lichteinwirkung macht dieses Leder zur optimalen Lösung für die Herstellung von Stühlen, Sesseln und Wohnaccessoires. Es handelt sich um ein vollnarbiges Leder mit einer Stärke von 1,3-1,5 mm, semi-anilin, chromgegerbt. Das Brandverhalten entspricht den Normen BS 5852 (Cigarette and Match), CAL TB 117, UNI EN 1021-1, UNI EN 1021-2 und NFPA 260/UFAC.

FLARE LEDER

Ein Leder mit weichem, umhüllendem Griff und einem leicht „schreibenden“ Effekt, das Licht- und Schattenspiele erzeugt und den bezogenen Flächen Tiefe verleiht. Die Anilin-Fassfärbung unterstreicht die hohe Qualität dieses Leders und verleiht ihm Weichheit, Eleganz und Glanz. Es handelt sich um ein vollnarbiges Leder mit einer Stärke von 1,3-1,5 mm, anilingefärbt, chromgegerbt. Das Brandverhalten entspricht den Normen BS 5852 (Cigarette and Match), CAL TB 117, UNI EN 1021-1, UNI EN 1021-2 und NFPA 260/UFAC.

RIDGE LEDER

Ridge ist ein Rindsleder mit weichem, vollgriffigem Touch und gleichmäßiger Oberfläche. Es wird durch das innovative und nachhaltige Olivenleder®-Gerbverfahren hergestellt – ganz ohne Chrom und Glutaraldehyd. Stattdessen kommen natürliche Gerbstoffe aus Rückständen der Olivenölproduktion zum Einsatz, was diesen Prozess besonders umweltfreundlich und ressourcenschonend macht. Das Leder hat eine Stärke von 1,2 bis 1,4 mm und ist durchgefärbt mit pigmentierter Anilin-Oberfläche, was für eine gleichmäßige, langlebige Farbgebung sorgt und gleichzeitig eine gute Atmungsaktivität bewahrt. Technische Eigenschaften: Entspricht den Anforderungen folgender Brandschutznormen: BS 5852 (Zigarette und Streichholz-Test) CAL TB 117 UNI EN 1021-1 und 1021-2 FTP Code 2010 – Teil 8.

SIMILICUIR

Matériel de dernière génération entièrement réalisé en Italie et sans aucun élément d'origine animale, composé de polyester 8%, polyuréthane 4%, pvc 88%, composition textile: polyester 100%. Produit exclusif Rimadesio, résistant et très performant, sans orthophtalates, conformément au Règlement européen Reach pour la protection de la santé et de l'environnement des risques causés par les substances chimiques. Chaque phase de production du similicuir Rimadesio se conforme aux réglementations environnementales en vigueur et de gestion de la qualité.

CUIR

Véritable cuir sellier bovin naturel, épaisseur de 1,8/2,0 mm, obtenu par le processus de tannage aux sels de chrome. La surface est pigmentée pour obtenir les différents couleurs du catalogue. La surface du cuir peut présenter de petites imperfections et des cicatrices, caractéristiques qui soulignent l'origine tout à fait naturelle du cuir et, en tant que telles, ne diminuent pas sa valeur mais exaltent sa beauté et ne sont pas considérées comme des défauts. Coutures en polyester. Réaction au feu conforme aux normes BS 5852 Cigarette and Match, Cal TB 117 et UNI EN 9175-2010 2.

CUIR BLAZE

Blaze est un cuir à grain naturel et légèrement accentué. Les caractéristiques de résistance aux taches et à la lumière font de ce cuir une solution optimale pour la confection de chaises, fauteuils et accessoires d'ameublement. Cuir pleine fleur de 1,3 à 1,5 mm d'épaisseur, semi-aniline, tanné aux sels de chrome. Réaction au feu conforme aux normes BS 5852 Cigarette and Match, CAL TB 117, UNI EN 1021-1, UNI EN1021-2 e NFPA 260/UFAC..

CUIR FLARE

Cuir caractérisé par une main douce et enveloppante et un effet légèrement écrit, capable de créer des effets de clair-obscur en donnant de la profondeur aux surfaces qu'il recouvre. La teinture à l'aniline en barrique définit sa qualité supérieure, lui conférant douceur, élégance et brillance. Cuir pleine fleur de 1,3 à 1,5 mm d'épaisseur, aniline, tanné aux sels de chrome. Réaction au feu conforme aux normes BS 5852 Cigarette and Match, CAL TB 117, UNI EN 1021-1, UNI EN1021-2 et NFPA 260/UFAC.

CUIR RIDGE

Ridge est un cuir à la main douce et pleine. L'innovant tannage Olivenleder® rend ce cuir durable, sans chrome et sans glutaraldéhyde, en exploitant les propriétés tannantes naturelles des olives, grâce à la récupération vertueuse des déchets générés par les moulins lors du pressage. Cuir de 1,2 à 1,4 mm d'épaisseur, pigmenté à l'aniline en passant, tanné Olivenleder®. Réaction au feu conforme aux normes BS 5852 Cigarette and Match, CAL TB 117, UNI EN 1021-1, UNI EN 1021-2 et FTP CODE 2010 PART 8.

SÍMIL CUERO

Material de última generación fabricado íntegramente en Italia y libre de componentes de origen animal, compuesto por: 8% poliéster, 4% poliuretano, 88% PVC, composición textil: 100% poliéster. Producto exclusivo Rimadesio, resistente y de altas prestaciones, libre de ortofalatos, en línea con el reglamento europeo Reach para la protección de la salud y el medio ambiente frente a los riesgos de las sustancias químicas. Cada fase de producción del simil cuero Rimadesio cumple con las normativas vigentes en materia ambiental y de gestión de la calidad.

CUERO

Piel bovina natural auténtica, de 1,8/2,0 mm de grosor, obtenida mediante un proceso de curtido con cromo. La superficie está pigmentada para obtener los distintos colores del catálogo. La superficie de la piel puede presentar pequeñas imperfecciones y cicatrices, características que subrayan su origen completamente natural y, por lo tanto, no disminuyen su valor, sino que realzan su belleza y no se consideran defectos. Costuras de poliéster. Reacción al fuego conforme a las normas BS 5852 Cigarette and Match, Cal TB 117 y UNI EN 9175-2010 2.

PIEL BLAZE

Blaze es una piel con una textura natural ligeramente acentuada. Su resistencia a las manchas y a la luz lo convierte en una excelente solución para la fabricación de sillas, sillones y accesorios de decoración. Piel con un grosor de 1,3-1,5 mm, curtido con semi-anilina y curtida en cromo. Cumple con las normas de reacción al fuego BS 5852 Cigarette and Match, CAL TB 117, UNI EN 1021-1, UNI EN 1021 -2 y NFPA 260/UFAC.

PIEL FLARE

Piel caracterizada por un tacto suave y envolvente y un ligero efecto texturizado, capaz de crear clarosucros que aportan profundidad a las superficies que recubre. El tinte con anilina define su calidad superior, aportando suavidad, elegancia y brillo. Piel con un grosor de 1,3-1,5 mm, curtido con anilina y cromo. Reacción al fuego conforme a las normas BS 5852 Cigarette and Match, CAL TB 117, UNI EN 1021-1, UNI EN 1021 -2 y NFPA 260/UFAC.

PIEL RIDGE

Ridge es una piel suave y con cuerpo. El innovador proceso de curtido Olivenleder® lo convierte en un cuero sostenible, sin cromo ni glutaraldehído, aprovechando las propiedades curtiencas naturales de las aceitunas gracias a la eficiente recuperación de los residuos generados por los molinos durante el prensado. Cuero con un grosor de 1,2-1,4 mm, pigmentado con anilina, curtido Olivenleder®. Reacción al fuego conforme a las normas BS 5852 Cigarette and Match, CAL TB 117, UNI EN 1021-1, UNI EN 1021-2 y FTP CODE 2010 PARTE 8.

ИСКУССТВЕННАЯ КОЖА

Материал последнего поколения, произведенный полностью в Италии и не содержащий компонентов животного происхождения, состоит из полиэстера 8%, полиуретана 4%, пвх 88%, тканевая основа – полиэстер 100%. Эксклюзивный продукт Rimadesio, прочный и высокоэффективный, не содержащий орто-фталатов, в соответствии с европейским регламентом Reach по защите здоровья и окружающей среды от рисков, связанных с химическими веществами. Каждый этап производства искусственной кожи Rimadesio соответствует действующим стандартам в области экологии и управления качеством.

КОЖА

Настоящая коровья кожа толщиной от 1,8 до 2,0 мм, обработанная методом хромового дубления. Поверхность окрашивается в различные цвета,

представленные в каталоге. На поверхности кожи могут присутствовать небольшие неровности и рубцы. Они являются характерными особенностями материала, подчеркивающими его полностью натуральное происхождение и красоту, нисколько не умаляют ее ценность и не являются дефектами. Швы выполнены полиэстерной нитью. Огнеупорные свойства в соответствии с нормативными стандартами BS 5852 Cigarette and Match (для сигарет и спичек), CAL TB 117 и UNI EN 9175-2020 2

КОЖА BLAZE

Blaze – это кожа с естественной, слегка подчеркнутой, зернистой фактурой. Она устойчива к пятнам и световому воздействию и прекрасно подходит для отделки стульев, кресел и мебельных аксессуаров. Полуанилиновая лицевая кожа толщиной от 1,3 до 1,5 мм хромового дубления. Огнеупорные свойства в соответствии с нормативными стандартами BS 5852 Cigarette and Match (для сигарет и спичек), CAL TB 117, UNI EN 1021-1, UNI EN1021-2 и NFPA 260/UFAC.

КОЖА FLARE

Кожа с характерно мягкой и уютной, слегка бархатистой поверхностью, образующей светотеневые эффекты, которые придают глубину покрываемым элементам. Анилиновое окрашивание методом погружения в бочку обеспечивает превосходное качество материала, мягкость и элегантный блеск. Анилиновая лицевая кожа толщиной от 1,3 до 1,5 мм хромового дубления. Огнеупорные свойства в соответствии с нормативными стандартами BS 5852 Cigarette and Match (для сигарет и спичек), CAL TB 117, UNI EN 1021-1, UNI EN1021-2 и NFPA 260/UFAC.

КОЖА RIDGE

Ridge – это мягкая лицевая кожа. Она обработана экологичным и инновационным методом дубления Olivenleder® без применения хрома и глутаральдегида, в котором отлично используются отходы маслоотжимных предприятий и естественные дубильные свойства оливок. Кожа толщиной от 1,2 до 1,4 мм, окрашенная анилиновыми красителями проникающим методом и дубленая по технологии Olivenleder®. Огнеупорные свойства в соответствии с нормативными стандартами BS 5852 Cigarette and Match (для сигарет и спичек), CAL TB 117, UNI EN 1021-1, UNI EN1021-2 и FTP CODE 2010 PART 8.

仿真皮革

最新一代的材质、不含动物成分、纯意大利制造，成分为：8% 聚酯纤维，4% 聚氨酯，88% PVC，织物成分：100% 聚酯纤维。其为 Rimadesio 的独家产品，特性为结实、极为耐用、不含邻苯二甲酸，符合欧盟 Reach 法规之健康与环境免受化学物质危害保护之相关规定。Rimadesio 仿真皮革的每道生产程序均符合目前的环境与质量管理相关规定。

牛皮皮革

天然真牛皮皮革，厚度为 1.8 - 2.0 毫米，采用铬鞣工艺制成。其表面以染色处理工艺的加工，旨在打造出产品目录上所呈现的各式色彩。皮革表面可能会有细小的瑕疵和划痕，这些特征彰显出纯天然皮革的原始本质，衬托材质之美，其并不减损皮革价值，亦不属于缺陷。缝线的材质为聚酯纤维。火灾反应符合《香烟和火柴》(Cigarette and Match) BS 5852、Cal TB 117 和 UNI EN 9175-2010 2 的标准。

BLAZE LEATHER

Blaze 皮革具有带微妙沙凸效果的自然纹理。这款皮革具备防污与耐光的特性，因而成为座椅、扶手椅和家具配件解决方案的理想之选。半苯胺的铬鞣全粒面皮革，厚 1.3 - 1.5 毫米。火灾反应符合《香烟和火柴》(Cigarette and Match) BS 5852、CAL TB 117、UNI EN 1021-1、UNI EN1021-2 和 NFPA 260/UFAC 的标准。

FLARE LEATHER

这款皮革的特点是手感柔软、具包裹感，略带丝绒质感，可为包覆的各式表面创造明暗效果和赋予深度。筒子苯胺染色的加工工艺奠定了 Pelle Flare 精美上乘的品质，赋予其柔韧手感、典雅气息与光泽效果。火灾反应符合《香烟和火柴》(Cigarette and Match) BS 5852、CAL TB 117、UNI EN 1021-1、UNI EN 1021-2 和 NFPA 260/UFAC 的标准。

RIDGE LEATHER

Ridge 皮革手感柔软、饱满。创新的 Olivenleder® 鞣革制剂赋予这款皮革可持续性，且不含铬和戊二醛；Olivenleder® 为一款将压榨橄榄油过程中所产生的废料进行良性回收后，从橄榄中提取出的天然鞣液。皮革厚度为 1.2 - 1.4 毫米，以苯胺颜料进行染色处理，使用 Olivenleder® 鞣革制剂。火灾反应符合《香烟和火柴》(Cigarette and Match) BS 5852、CAL TB 117、UNI EN 1021-1、UNI EN 1021-2 和 FTP CODE 2010 PART 8.的标准。

GUIDE TO RIMADESIO QUALITY

FABRIC

Fabrics produced in Italy with high quality fibres. Any color and hue irregularities, derived from different production batches, are not to be considered defects. The uniformity of shades is not guaranteed in case of replacements or additions. The fabrics can also undergo changes in hue over time due to the natural action of sunlight.

TECH FABRIC

Composition: Trevira CS polyester 100%. Resistance to scraping, Martindale test 75.000 rubs. Resistance to pilling, class 4/5. Resistance to light, 5/6. Reaction to fire conforms to BS 5852 Cigarette test, CAL TB 117 and CRIB 5.

LUX FABRIC

Composition: cotton 75%, silk 25%. Resist-ance to light, 4/5. Lux fabric is a sustainable and environmentally friendly material with recycled cotton fibers and biodegradable silk.

MATERIAL FABRIC

Composition: 43% viscose, 36% cotton, 15% polyester, 6% linen. Resistance to scraping, Martindale test 20.000 rubs. Resistance to pilling, class 4. Resistance to light, 4/5. Reaction to fire conforms to BS 5852 Cigarette test and CAL TB 117.

NOMAD FABRIC

Composition: viscose 30%, wool 16%, linen 13%, cotton 12%, polyamide 10%, polyester 9%, silk 6%, acrylic 4%. Resistance to scraping, Martindale test 30.000 rubs. Resistance to pilling, class 3/4. Resistance to light, 5/6. Reaction to fire conforms to BS 5852 Cigarette test. CAL TB 117.

BOUCLÉ FABRIC

Composition: acrylic 35%, virgin wool 30%, polyester 25%, cotton 10%. Resistance to scraping, Martindale test 80.000 rubs. Resistance to pilling, class 4. Resistance to light, 5/6. Reaction to fire conforms to BS 5852 Cigarette and Match test and CAL TB 117.

GROOVE FABRIC

Composition: acrylic 37%, polyester 30%, cotton 18%, wool 13%, polyamide 2%. Resistance to scraping, Martindale test 80.000 rubs. Resistance to pilling, class 4/5. Resistance to light, 5/6. Reaction to fire conforms to BS 5852 Cigarette test and CAL TB 117.

PLAIN FABRIC

Composition: viscose 38%, polyester 24%, cotton 20%, linen 18%. Resistance to scrap- ing, Martindale test 24.000 rubs. Resistance to pilling, class 4. Resistance to light <4. Reaction to fire conforms to: BS 5852 Ciga-rette and Match test, Cal TB 117

RAFIA

The Rafia finish is an exclusive interpreta- tion of a natural material. The high-quality fiber weave makes this finish versatile and durable. Composition: viscose 54%, cotton 46%. Backing: 100% cotton Resistance to scraping, Martindale test 10.000 rubs

CORD

Cord is a Rimadesio finishing made by a rope with three strands Natural colour cord is realized in braided cellulose fibre. Black colour cord is realized in synthetic braided fibre. Wear, fraying and elongation of the material are intrinsic characteristics of the product itself. Fabrics with intense colors and denim dyes can stain and dis- color the cord in natural color. The cord products are woven by hand and therefor may present slight irregularities and differ- ences between severalarticles of the same series.

TESSUTO

Tessuti prodotti in Italia con fibre di elevata qualità. Eventuali irregolarità cromatiche e tonalità, derivati da diversi lotti di produ- zione, non sono da considerarsi difetti. Non è garantita l’uniformità di tonalità in caso di sostituzioni o completamenti. I tessuti possono inoltre subire variazioni di tonalità nel tempo a causa della naturale azione della luce solare.

TESSUTO TECH

Composizione: poliestere 100% Trevira CS. Resistenza all’abrasione, test Martin- dale 75.000 giri. Resistenza al pilling, classe 4/5. Resistenza alla luce, 5/6 Resistenza al fuoco, BS 5852 Cigarette test, CAL TB 117, CRIB 5.

TESSUTO LUX

Composizione: cotone 75%, seta 25%. Resistenza alla luce, 4/5. Il tessuto Lux è un materiale sostenibile ed ecologico con fibre di cotone riciclato e di seta biode gradabili.

TESSUTO MATERIAL

Composizione: viscosa 43%, cotone 36%, poliestere 15%, lino 6%. Resistenza all’abrasione, test Martindale 20.000 giri. Resistenza al pilling, classe 4. Resistenza alla luce, 4/5. Resistenza al fuoco, BS 5852 Cigarette test, CAL TB 117.

TESSUTO NOMAD

Composizione: viscosa 30%, lana 16%, lino 13%, cotone 12%, poliammide 10%, polies- tere 9%, seta 6%, acrilico 4%. Resistenza all’abrasione, test Martindale 30.000 giri. Resistenza al pilling classe 3/4. Resistenza alla luce 5/6. Conforme alle normative BS 5852 Cigarette test, CAL TB 117.

TESSUTO BOUCLÉ

Composizione: acrilico 35%, lana 30%, poliestere 25%, cotone 10%. Resistenza all’abrasione: test Martindale 80.000 gi-ri Resistenza al pilling classe 4. Resistenza alla luce 5/6. Conforme alle normative BS 5852 Cigarette and Match test, CAL TB 117.

TESSUTO GROOVE

Composizione: acrilico 37%, poliestere 30%, cotone 18%, lana 13%, poliammide 2%. Resistenza all’abrasione, test Martindale 80.000 giri. Resistenza al pilling: classe 4/5. Resistenza alla luce 5/6. Conforme alle normative BS 5852 Cigarette test, CAL TB 117.

TESSUTO PLAIN

Composizione: viscosa 38%, poliestere 24% cotone 20%, lino 18%. Resistenza all’abrasione, test Martindale 24.000 giri. Resistenza al pilling classe 4. Resistenza alla luce <4. Conforme alle normative BS 5852 Cigarette e Match, Cal TB 117.

RAFIA

La finitura Rafia rappresenta un’esclusiva interpretazione di un materiale naturale. L’intreccio di fibre di alta qualità rendono questa finitura versatile e resistente. Composizione: viscosa 54%, cotone 46%. Backing 100% cotone. Resistenza all’abrasione test Martindale 10.000 giri.

CORDA

Cord è una finitura Rimadesio composta da una corda a tre capi. Corda in colore naturale realizzata in fibra di cellulosa intrecciata. Corda in colore nero realizzata in fibra sintetica intrecciata. L’usura, lo sfilacciamento e l’allungamento del materiale sono caratteristiche intrinseche del prodotto stesso. Tessuti dai colori intensi e tinteure di jeans possono macchi-are e scolorire la corda in colore naturale. I prodotti in corda vengono intrecciati a mano e come tali potrebbero presentare delle leggere irregolarità e differenze tra più articoli della stessa serie.

STOFF

Stoffe, die in Italien aus hochwertigen Fasern hergestellt werden. Mögliche Farb- und Tonabweichungen, die durch unterschiedliche Produktionschargen entstehen, sind keine Mängel. Eine gleichmäßige Farbtonübereinstimmung bei Ersatzlieferungen oder Ergänzungen kann nicht garantiert werden. Die Stoffe können zudem im Laufe der Zeit Farbveränderungen aufgrund des natürlichen Einflusses von Sonnenlicht erfahren.

STOFF TECH

Zusammensetzung: 100% Polyester Trevira CS. Abriebfestigkeit, Martindale-Test: 75.000 Umdrehungen. Pilling Festigkeit, Klasse 4/5. Lichtbeständigkeit, 5/6. Brand- beständigkeit: BS 5852 (Zigaretten-Test), CAL TB 117, CRIB 5.

STOFF LUX

Zusammensetzung: 75% Baumwolle, 25% Seide. Lichtbeständigkeit: 4/5. Der Lux- Stoff ist ein nachhaltiges und ökologisches Material aus recycelter Baumwolle und biologisch abbaubarer Seide.

STOFF MATERIAL

Zusammensetzung: 43% Viskose, 36% Baumwolle, 15% Polyester, 6% Leinen. Abriebfestigkeit, Martindale-Test: 20.000 Umdrehungen. Pilling Festigkeit, Klasse 4. Lichtbeständigkeit, 4/5. Brandfestigkeit: BS 5852 (Zigaretten-Test), CAL TB 117.

STOFF NOMAD

Zusammensetzung: 30% Viskose, 16% Wolle, 25 % Polyester, 10 % Baumwolle, 10% Polyamid, 9% Polyester, 6% Seide, 4% Acryl. Abriebfestigkeit, Martindale-Test: 30.000 Umdrehungen. Pilling Festigkeit, Klasse 3/4. Lichtbeständigkeit, 5/6. Konform mit den Normen BS 5852 (Zigaretten-Test), CAL TB 117.

STOFF BOUCLÉ

Zusammensetzung: 35 % Acryl, 30 % Wolle, 25 % Polyester, 10 % Baumwolle. Abriebfestigkeit, Martindale-Test: 80.000 Umdrehungen. Pilling Festigkeit, Klasse 4. Lichtbeständigkeit, 5/6. Konform mit den Normen BS 5852 (Zigaretten- und Streichholz-Test), CAL TB 117.

STOFF GROOVE

Zusammensetzung: 37 % Acryl, 30 % Polyester, 18 % Baumwolle, 13 % Wolle, 2 % Polyamid. Abriebfestigkeit, Martindale-Test: 80.000 Umdrehungen. Pilling Festigkeit, Klasse 4/5. Lichtbeständigkeit, 5/6. Konform mit den Normen BS 5852 (Zigaretten-Test), CAL TB 117.

STOFF PLAIN

Zusammensetzung: 38 % Viskose, 24 % Polyester, 20 % Baumwolle, 18 % Leinen. Abriebfestigkeit, Martindale-Test: 24.000 Umdrehungen. Pilling Festigkeit, Klasse 4. Lichtbeständigkeit, <4. Konform mit den Normen BS 5852 (Zigaretten- und Streichholz-Test), Cal TB 117.

RAFIA

Die Rafia-Oberfläche stellt eine exklusive Interpretation eines natürlichen Materials dar. Das Fasergeweicht aus hochwertigen Materialien macht diese Oberfläche vielseitig und widerstandsfähig. Zusam- mensetzung: 54 % Viskose, 46 % Baumwolle. Rückseite: 100 % Baumwolle. Abriebfestigkeit, Martindale-Test: 10.000 Umdrehungen.

Die Rafia-Oberfläche stellt eine exklusive Interpretation eines natürlichen Materials dar. Das Fasergeweicht aus hochwertigen Materialien macht diese Oberfläche vielseitig und widerstandsfähig. Zusam- mensetzung: 54 % Viskose, 46 % Baumwolle. Rückseite: 100 % Baumwolle. Abriebfestigkeit, Martindale-Test: 10.000 Umdrehungen.

Die Rafia-Oberfläche stellt eine exklusive Interpretation eines natürlichen Materials dar. Das Fasergeweicht aus hochwertigen Materialien macht diese Oberfläche vielseitig und widerstandsfähig. Zusam- mensetzung: 54 % Viskose, 46 % Baumwolle. Rückseite: 100 % Baumwolle. Abriebfestigkeit, Martindale-Test: 10.000 Umdrehungen.

CORD

Cord ist eine Rimadesio–Oberfläche, die aus einer dreifädigen Schnur besteht. Die Schnur in naturfarbenen wird aus geflochtenen Zellulosefasern hergestellt, während die Schnur in schwarz aus synthetischen, geflochtenen Fasern besteht. Abnutzung, Ausfransen und Dehnung des Materials sind charakteristische Merkmale des Produkts. Stoffe mit intensiven Farben und Jeans können die naturfarbene Schnur verfärben und abfärben. Die Schnurprodukte werden von Hand geflochten, sodass leichte Unregelmäßigkeiten und Farbabweichungen zwischen verschiedenen Artikeln derselben Serie auftreten können.

TISSU

Tissus fabriqués en Italie avec des fibres de haute qualité. Éventuelles irrégularités chromatiques et les nuances, suite de différents lots de production, ne sont pas considérés comme des défauts. L’uniformité des teintes n’est pas garantie en cas de remplacement ou commande supplémentaires. Les tissus peuvent également changer de teinte au fil du temps en raison de l’action naturelle de la lumière du soleil.

TISSU TECH

Composition : 100% polyester Trevira CS. Résistance à l’abrasion, test Martindale 75.000 tours. Résistance au pilling, classe 4/5. Résistance à la lumière, 5/6. Résis- tance au feu, BS 5852 Cigarette test, CAL TB 117, CRIB 5.

TISSU LUX

Composition : coton 75%, soie 25%. Ré- sistance à la lumière, 4/5. Le tissu Lux est un matériau durable et écologique avec des fibres de coton recyclé et de soie bio- dégradables.

TISSU MATERIAL

Composition : viscose 43%, coton 36%, polyester 15%, lin 6%. Résistance à l’abrasion, test Martindale 20.000 tours. Résistance au boulochage, classe 4. Résistance à la lumière, 4/5. Résistance au feu, BS 5852 Cigarette test, CAL TB 117.

TISSU NOMAD

Composition : viscose 30%, laine 16%, lin 13%, coton 12%, polyamide 10%, polyester 9%, soie 6%, acrylique 4%. Résistance à l’abrasion, test Martindale 30.000 tours. Résistance au pilling classe 3/4. Résistance à la lumière 5/6. Conforme aux normes BS 5852 Cigarette test, CAL TB 117.

TISSU BOUCLÉ

Composition : viscose 43%, coton 36%, polyester 25%, coton 10%. Résistance à l’abrasion : test Martindale 80.000 tours. Résistance au pilling classe 4. Résistance à la lumière 5/6. Conforme aux normes BS 5852 Cigarette and Match test, CAL TB 117.

TISSU GROOVE

Composition : acrylique 37%, polyester 30%, coton 18%, laine 13%, polyamide 2%. Ré- sistance à l’abrasion, test Martindale 80.000 tours. Résistance au pilling : classe 4/5. Résistance à la lumière 5/6. Conforme aux normes BS 5852 Cigarette test, CAL TB 117.

TISSU PLAIN

Composition : viscose 38%, polyester 24%, coton 20%, lin 18%. Résistance à l’abrasion, test Martindale 24000 tours. Résistance au boulochage classe 4. Résistance à la lumière <4. Conforme aux normes BS 5852 Cigarette e Match, Cal TB 117.

RAFIA

La finition Rafia est une interprétation exclusive d’un matériau naturel. Le tissage de fibres de haute qualité rend cette finition polyvalente et durable. Composition : vis- cose 54%, coton 46%. Support 100% co- ton. Résistance à labrasion Martindale 10.000 tours.

CORDE

Corde est une finition Rimadesio composée d’une corde à trois fils. Corde de couleur naturelle en fibre de cellulose tressée. Corde de couleur noire en fibre synthétique tressée. L’usure, lefeilochage et l’allongement du matériau sont des caractéristiques intrinsèques du produit lui-même. Les tissus aux couleurs intenses et les teintures de jeans peuvent tacher et décolorer la corde en couleur naturelle. Les produits en corde sont tressés à la main et peuvent présenter de légères irrégularités et différences entre plusieurs articles de la même série.

TEJIDO

Tejidos producidos en Italia con fibras de alta calidad. Cualquier irregularidad en el color y la tonalidad, resultante de diferentes lotes de producción, no se considerará un defecto. No se garantiza la uniformidad del tono en caso de reemplazos o amplia- ciones. Los tejidos también pueden sufrir variaciones de tonalidad con el tiempo debido a la acción natural de la luz solar.

TEJIDO TECH

Composición: 100 % poliéster Trevira CS. Resistencia a la abrasión (prueba Martindale de 75 000 vueltas). Resistencia al pilling (clase 4/5). Resistencia a la luz (clase 5/6). Resistencia al fuego (Cigarette test BS 5852, CAL TB 117, CRIB 5).

TEJIDO LUX

Composición: 75 % algodón, 25 % seda. Resistencia a la luz: 4/5. El tejido Lux es un material sostenible y ecológico con fibras de algodón reciclado y seda biodegradable.

TEJIDO MATERIAL

Composición: viscosa 43%, algodón 36%, poliéster 15%, lino 6%. Resistencia a la abrasión: prueba Martindale de 20.000 vueltas. Resistencia al pilling: clase 4. Resistencia a la luz: 4/5. Resistencia al fuego: Cigarette test BS 5852, CAL TB 117.

TEJIDO NOMAD

Composición: viscosa 30%, lana 16% lino 13%, algodón 12%, poliamida 10%, poliéster 9%, seda 6%, acrilico 4%. Resistencia a la abrasión (prueba Martindale de 30.000 vueltas). Resistencia al pilling (clase 3/4). Resistencia a la luz (clase 5/6). Cumple con la norma BS 5852, Cigarette test (CAL TB 117, CRIB 5).

TEJIDO BOUCLÉ

Composición: acrílico 35%, lana 30%, poliéster 25%, algodón 10%. Resistencia a la abrasión: Prueba Martindale de 80.000 vueltas. Resistencia al pilling clase 4. Resistencia a la luz 5/6. Cumple con la norma BS 5852, Cigarette and Match test, CAL TB 117.

TEJIDO GROOVE

Composición: acrílico 37%, poliéster 30%, algodón 18%, lana 13%, poliamida 2%. Resistencia a la abrasión: prueba Martindale de 80.000 vueltas. Resisten- cia al pilling: clase 4/5. Resistencia a la luz: 5/6. Cumple con la norma BS 5852, Cigarette test, CAL TB 117.

TEJIDO PLAIN

Composición: viscosa 38%, poliéster 24%, algodón 20%, lino 18%. Resistencia a la abrasión (prueba Martindale de 24.000 vueltas). Resistencia al pilling clase 4. Solidez a la luz <4. Cumple con la norma BS 5852 sobre Cigarette and Match, Cal TB 117.

RAFIA

El acabado Rafia representa una interpretación exclusiva de un material natural. El entretejido de fibras de alta calidad hace que este acabado sea versátil y resistente. Composición: 54% viscosa, 46% algodón. Reverso: 100% algodón. Resistencia a la abrasión: prueba Martindale de 10 000 vueltas.

CUERDA

La cuerda es un acabado de Rimadesio compuesto por un cordón de tres hilos. El cordón de color natural está hecho de fibra de celulosa tejida. El cordón de color negro está hecho de fibra sintética tejida. El desgaste, el deshilachado y el estramiento del material son características intrínsecas del producto. Las telas con colores intensos y los tintes de tejanos pueden manchar y decolorar el cordón de color natural. Los productos de cordón están tejidos a mano, por lo que pueden presentar ligeras irregularidades y diferencias entre los artículos de la misma serie.

ТКАНЬ

Текстильные материалы производятся в Италии из высококачественных волокон. Любые вариации расцветок и оттенков в материалах из разных производствен- ных партий не считаются дефектами. При замене или дополнительной постав- ке невозможно гарантировать точное соответствие тона. Со временем расцветки текстиля могут изменяться под естественным воздействием солнечного света.

ТЕХНИЧЕСКАЯ ТКАНЬ

Состав: 100% полиэстер Trevira CS. Устойчивость к истиранию, тест Мартин- дейла 75 000 циклов. Сопротивление пиллингу, класс 4/5. Светостойкость, 5/6. Огнеупорные свойства в соответствии со стандартами BS 5852 (испытание сигаретой), CAL TB 117, CRIB 5.

ТЕКСТИЛЬ LUX

Состав: хлопок 75%, шелк 25%. Светостойкость, 4/5. Полотно Lux - это экологичный и безопасный для окружающей среды материал, в состав которого входят вторично перерабо- танный хлопок и биоразлагаемые шелковые волокна.

ТЕКСТИЛЬ MATERIAL

Состав: viscosa 43%, хлопок 36%, полиэстер 15%, лен 6%. Устойчивость к истиранию, тест Мартиндейла 20 000 циклов. Сопротивление пиллингу, класс 4. Светостойкость, 4/5. Огнеупорные свойства в соответствии со стандар- тами BS 5852 (испытание сигаретой), CAL TB 117.

ТЕКСТИЛЬ NOMAD

Состав: viscosa 30%, шерсть 16%, лен 13%, хлопок 12%, полиамид 10%, полиэстер 9%, шелк 6%, акрил 4%. Устойчивость к истиранию, тест Мартиндейла 30 000 циклов. Сопротивление пиллингу, класс 3/4. Светостойкость 5/6. Соответствует стандартам BS 5852 (испытание сигаретой), CAL TB 117.

ТКАНЬ BOUCLÉ

Состав: акрил 35%, шерсть 30%, полиэ- стер 25%, хлопок 10%. Устойчивость к истиранию: тест Мартиндейла 80 000 циклов. Класс устойчивости к пиллингу 4. Светостойкость 5/6. Соответствует стандартам BS 5852 (испытание сигаретой и спичками), CAL TB 117.

ТЕКСТИЛЬ GROOVE

Состав: акрил 37%, полиэстер 30%, хлопок 18%, шерсть 13%, полиамид 2%. Устойчивость к истиранию, тест Мартин- дейла 80 000 об/мин. Сопротивление пиллингу, класс 4/5. Светостойкость 5/6. Соответствует стандартам BS 5852 (испытание сигаретой), CAL TB 117.

ТЕКСТИЛЬ PLAIN

Состав: viscosa 38%, полиэстер 24%, хлопок 20%, лен 18%. Устойчивость к истиранию, тест Мартиндейла 24 000 циклов. Сопротивление пиллингу, класс 4. Светостойкость <4. Соответствует стандартам BS 5852 (испытание сигаре- той и спичками), Cal TB 117.

RAFIA

Отделка Rafia - это эксклюзивная интерпретация натурального материала. Переплетенные волокна

высокого качества обеспечивают материалу универсальность и долговечность. Состав: viscosa 54%, хлопок 46%. Подкладка из 100% хлопка. Устойчивость к истиранию, тест Мартиндейла 10 000 циклов.

CORDA

Corda - разновидность отделки Rimadesio, выполненная из трехжильной веревки. Веревка естественной расцветки изготавливается из сплетенных целлюлозных волокон. Черная веревка выполнена из сплетенных синтетических волокон. Износ, взлохмачивание и вытягивание материала являются характерными свойствами изделия. Текстиль ярких расцветок, а также джинсовые красители могут оставлять пятна и вызывать выцветание веревки естественной расцветки. Веревочные изделия плетутся вручную, вследствие чего возможны незначительные неровности и различия между изделиями одной серии.

面料

我们的织物面料以意大利生产的优质纤维制成。任何色彩上的不规则性、于不同生产批次中所出现的色差和色调皆不应视作缺陷。因此，如需进行产品的更换或补充，将无法保证其色调一致性。织物面料的色泽随时间推移会产生变化，这是源自于阳光的自然作用。

TECH 面料

成分：100% Trevira CS 特雷维拉聚酯纤维。马丁代尔织物耐磨测试 75.000 次。织物抗起球测试，第 4/5 级。耐光性，5/6 具耐火性能，BS 5852 香烟测试、CAL TB 117、CRIB 5。

LUX 面料

成分：棉 75%、真丝 25%。耐光性，4/5 级。LUX 面料为 LUX 面料为一款可持续发展 and 生态环保的面料，由回收棉纤维和 可生物降解的蚕丝制成。

MATERIAL 面料

成分：粘胶纤维 43%、棉 36%、聚酯纤维 15%、亚麻 6%。马丁代尔织物耐磨测试 20.000 次。织物抗起球测试，第 4 级。耐光性：4/5。具耐火性能，BS 5852 香烟测试和 CAL TB 117 标准。

NOMAD 面料

成分：粘胶纤维 30%、羊毛 16%、亚麻 13%、棉 12%、聚酰胺 10%、聚酯纤维 9%、真丝 6%、腈纶 4%。马丁代尔织物耐 磨测试 30.000 次。织物抗起球测试第 3/4 级。耐光性 5/6 符合 BSBS 5852 香烟测试和 CAL TB 117 标准。

BOUCLÉ 面料

成分：腈纶 35%、羊毛 30%、聚酯纤维 25%、棉花 10%。耐磨性：马丁代尔测试 80.000 次抗起球性第 4 级。耐光性 5/6 。符合 BSBS 5852 《香烟和火柴》(Cigarette and Match) 测试和 CAL TB 117 标准。

GROOVE 面料

成分：腈纶 37%、聚酯纤维 30%、棉 18%、羊毛 13%、聚酰胺 2%。马丁代尔织物耐磨测试 80.000 次。织物抗起球测试：第 4/5 级。耐光性 5/6。符合 BSBS 5852 香烟测试和 CAL TB 117 标准。

PLAIN 面料

成分：粘胶纤维 38%、聚酯纤维 24%、棉 20%、亚麻 18%。马丁代尔织物耐磨测试 24.000 次。抗起球性 4 级。耐光性 < 4 。符合 BSBS 5852 《香烟和火柴》(Cigarette and Match) 和 CAL TB 117 标准。

RAFIA

Rafia 酒椰草饰面尽致演绎天然材质的独特风韵。该饰面以品质上乘的纤维交错编织而成，其特点为灵活百搭且经久耐用。成分：粘胶纤维 54%、棉 46%。100% 纯棉衬底。马丁代尔 织物耐磨测试 10.000 次。

CORDA

Rimadesio 的 Corda 饰面以三股绳制成。天然色版本的 Corda 采用编织的纤维素纤维而成。黑色版本的 Corda 采用编织的纤维素纤维而成。如有磨损、脱线和拉长等情形属产品本身的特性。颜色鲜艳的织物面料和牛仔布染料会污染天然色的编绳饰面，并使其褪色。编绳产品均以手工制作而成，因此同一系列的不同产品之间可能会存在细微的不规则性和差异。</

SYNTHETIC LEATHER



157 arena
158 agata
155 nube
154 argilla
160 miele
153 castoro
159 etna
156 rubens

HIDE LEATHER



C23 bianco ghiaccio
C17 sand
C29 toupè
C28 fango
C16 naturale
C22 caramello
C25 siena
C11 moka
C09 nero

BLAZE LEATHER



P001 arctic
P002 gardenia
P003 vanilla
P004 glacier
P005 fog
P006 bamboo

HIDE LEATHER



P007 lily
P008 caramel
P009 rust
P010 sunset
P011 driftwood
P012 bruno
P013 ghost
P014 midnight
P015 storm

FLARE LEATHER



P016 oat
P017 ecru
P018 nut
P019 dusk
P020 mars
P021 camel
P022 moss
P023 umber
P024 meteor
P025 anthracite
P026 basalt

RIDGE LEATHER

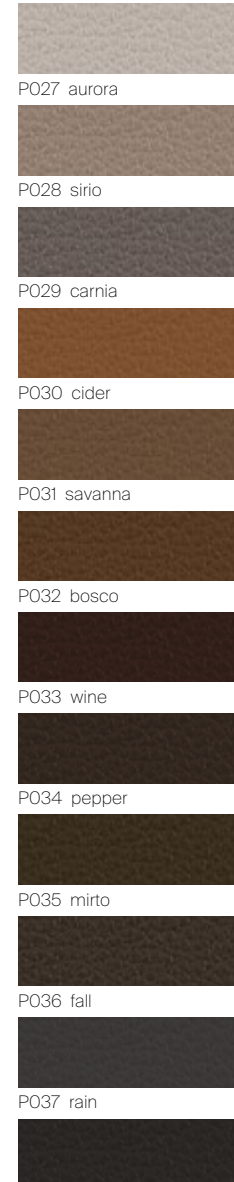

P027 aurora
P028 sirio
P029 carnia
P030 cider
P031 savanna
P032 bosco
P033 wine
P034 pepper
P035 mirto
P036 fall
P037 rain
P038 shade

TECH FABRIC

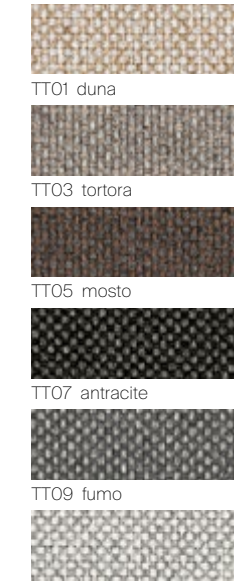

TT01 duna
TT03 tortora
TT05 mosto
TT07 antracite
TT09 fumo
TT10 ghiaccio



TT11 giada
TT19 canyon
TT20 dolomiti
TT21 cedro

NOMAD FABRIC



T200 jasper
T201 gobi
T202 ande
T203 elbrus
T204 ural
T205 sila

BOUCLÉ FABRIC



T206 loto
T207 almond
T208 crusca
T209 ginger
T210 fiume
T211 marea

GROOVE FABRIC



T212 luna
T213 jasmine
T214 fossil
T215 shadow
T216 polar
T217 onyx

PLAIN FABRIC



T218 elder
T219 acacia
T224 shell
T220 dust
T226 silt
T225 flax
T221 sage
T222 timo
T223 orion

LUX FABRIC



T006 gesso
T052 segale
T044 acciaio
T012 marmotta
T042 ruggine
T051 salvia

MATERIAL FABRIC



T020 nebbia
T019 papiro
T009 piuma
T017 roccia
T001 terracotta
T003 brandy
T018 tabacco

RAFIA



T133 magnolia
T134 desert
T101 natural
T115 stone
T102 sequoia

CORD



CD01 light
CD02 dark

Collection designed by Giuseppe Bavuso.

Art direction and graphic project: Juma
Render images: Suprema unlimited reality
Styling: Gaia Marchesini and Giordano Sarno

March 2026

RIMADESIO SPA
Via Furlanelli 96
20833 Giussano (MB) Italy
T +39 0362 3171
rimadesio@rimadesio.it

MILANO FLAGSHIP STORE
Via Visconti di Modrone 26
20122 Milano Italy
T +39 02 76280708
milano@rimadesio.it

LONDON FLAGSHIP STORE
83-85, Wigmore street
1WU 1DL London
T +44 2074 862193
london@rimadesio.co.uk

PARIS flagship store
25, Avenue Rapp
75007 Paris
T +33 171930682
paris@rimadesio.fr

New York flagship store
102 Madison Ave
New York, NY 10016
T +1 917 388 2650
newyork@rimadesio.us

MIAMI FLAGSHIP STORE
2601 Biscayne Blvd
33137 Miami
T +1 917 388 2650
miami@rimadesio.us

www.rimadesio.it



Follow us on Instagram, Facebook, LinkedIn,
WeChat, Weibo, Little Red Book.

AWARDS

1993	Siparium	Young & Design
2000	Zenit	Award KBB
2001	Zenit	selection Design Index ADI
2002	Siparium	Top100 Frames
2005	Graphis	selection Design Index ADI
2007	Vela	selection Design Index ADI
2008	Vela	mention XXI Premio Compasso d'Oro ADI
2015	Wind	winner Red Dot Award
2016	Cover	Best Furniture System AZ Award
2016	Alambra	selection Design Index ADI
2017	Sail	selection Design Index ADI
2017	Soho	Architectural products AZ awards
2017	Daimon	Interior Design Magazine Best of Year awards
2020	Modulor	People's Choice winner AZ Awards
2020	Modulor	Architectural Products Award of Merit AZ Awards
2020	Modulor	selection Design Index ADI
2021	Francis	selection Design Index ADI
2021	Modulor	LivingEtc Style Awards
2022	Maxi	selection Design Index ADI
2022	Aliante	finalist Interior's best of the Year awards
2022	Aliante	finalist A+Product awards
2023	Maxi	winner German Design Awards
2023	Radius	Architect's Newspaper's Best of Products Awards
2024	Aliante	German Design Awards
2025	Air system	winner German Design Awards

PATENTED:

Air System, Altair, Air, Radius, Aliante, Rialto, Maxi, Sail, Soho, Velaria, Stripe, Daimon, Graphis, Zen, Zen frame, Siparium, Moon, Vela, Luxor, Even, Aura, Spin, Link+, Planet, Flat, Alambra, Abacus living, Self, Cover, Zenit, Dress bold, Abacus, Sinua chair, Sinua armchair, Wabi, Nest, Sophis, Lambda, Hedon.

REGISTERED TRADEMARKS:

Rimadesio, Ecoloursystem, Litech, Siparium, Velaria, Abacus.